



**OF-SMD5060RGB-W**

## **Technical Datasheet**

5050 is thermal management characteristic is better than other LED Solutions. By package SMD design and good thermal emission material.

According to these advantages, it enables to apply various lighting applications and design solution, automotive lighting, and large size LCD backlight etc.

### **Application**

- Mobile phone flash
- Automotive interior / exterior lighting
- Automotive signal lighting
- Automotive forward lighting
- General Torch
- Architectural lighting
- LCD TV / Monitor Backlight
- Projector light source
- Traffic signals
- Task lighting
- Decorative / Pathway lighting
- Remote / Solar powered lighting
- Household appliances

## Features

1. PLCC LED dimensions: 5.0(L) x 5.0(W) x 1.8(H) mm
2. High intensity
3. Extremely wide view angle
4. Anti-electrostatic tape package
5. Reliable and stable

Part No.	OF-SMD5060RGB-W
----------	-----------------

Emitting Color	RGB
----------------	-----

## Package Dimension

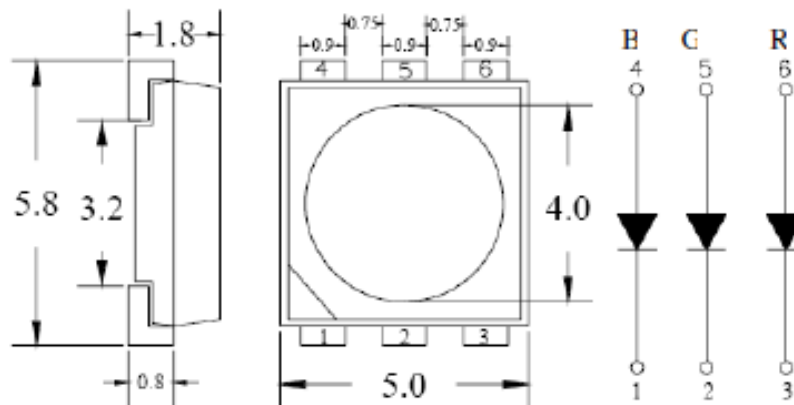

### Notes:

1. All dimensions are in mm.
2. Tolerance is  $\pm 0.25$ mm unless otherwise noted.

### Absolute Maximum Ratings at Ta=25°C

Parameter	MAX.	Unit
Peak Forward Current (1/10 Duty Cycle, 0.1ms Pulse Width)	50	mA
Continuous Forward Current	20	mA
Reverse Voltage	5	V
Operating Temperature Range	-25°C to +85°C	
Storage Temperature Range	-40°C to + 100°C	
Lead Soldering Temperature	260°C for 3 Seconds	

### Electrical Optical Characteristics at Ta=25°C

Parameter	Symbol	Min.	Typ.	Max.	Unit	Test Condition
Luminous Intensity	$I_{v(\text{Red})}$	400	600	--	mcd	$I_F = 20\text{mA}$ (Note 8)
	$I_{v(\text{Green})}$	400	600			
	$I_{v(\text{Blue})}$	100	200			
Wavelength	$\lambda d_{(\text{Red})}$	620	--	630	nm	$I_F = 20\text{mA}$
	$\lambda d_{(\text{Green})}$	515		525		
	$\lambda d_{(\text{Blue})}$	465		475		
Viewing Angle	$2\theta_{1/2}$	--	120	--	Deg	$I_F = 20\text{mA}$
Forward Voltage	$V_{F(\text{Red})}$	--	2.0	2.8	V	$I_F = 20\text{mA}$
	$V_{F(\text{Green})}$		3.2	4.0		
	$V_{F(\text{Blue})}$		3.2	4.0		
Reverse Current	$I_R$	--	--	50	$\mu\text{A}$	$V_R = 5\text{V}$

#### Notes:

- All dimensions are in millimeter. Tolerance is  $\pm 0.25\text{mm}$  (.01") unless others otherwise noted.
- WW maintains a tolerance of  $\pm 10\%$  on flux and power measurements.
- CCT  $\pm 5\%$  tester tolerance and  $\lambda d \pm 1\text{nm}$
- A tolerance of  $\pm 0.1\text{V}$  on forward voltage measurements
- View Angle maintains a tolerance of  $\pm 20^\circ$
- Specifications are subject to change without notice.
- These products are sensitive to static electricity; high standard of care must be fully taken when handling them. Particularly if an over-voltage that exceeds the Absolute maximum Rating of these products were applied, the overflow energy will cause damage to and possibly result in destruction of these products. Buyer shall take absolute secure countermeasures against static electricity and surge when handling these products.
- Luminous intensity is measured with a light sensor and filter combination that approximates the CIE eye-response curve.  $\theta_{1/2}$  is the off-axis angle at which the luminous intensity is half the axial luminous intensity.
- It use many parameters that correspond to the CIE 1931 2°  
X, Y, and Z are CIE1931 2° values of Red, Green and Blue content of the measurement.

#### \* Caution

- Please do not drive at Peak Forward Current more than 5 sec.

## Typical Characteristics

### Typical Electrical/Optical Characteristic Curves

(25°C Ambient Temperature Unless Otherwise Noted)

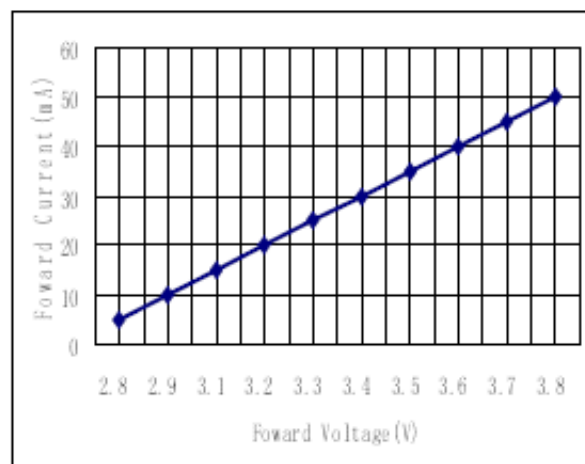
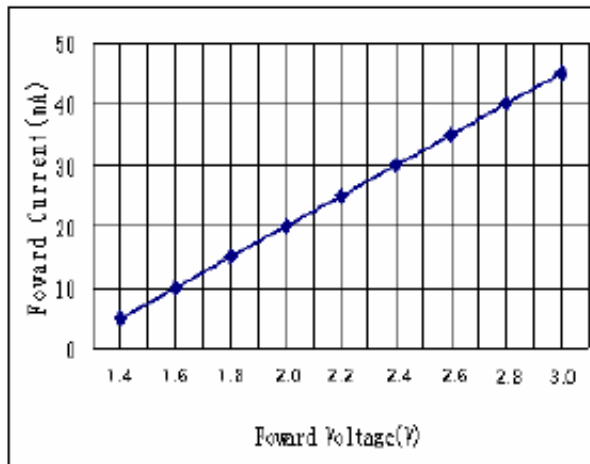
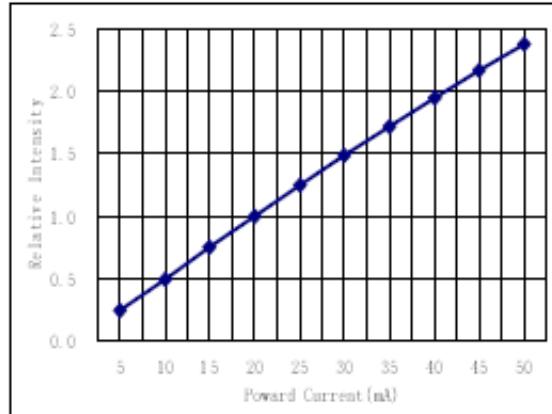
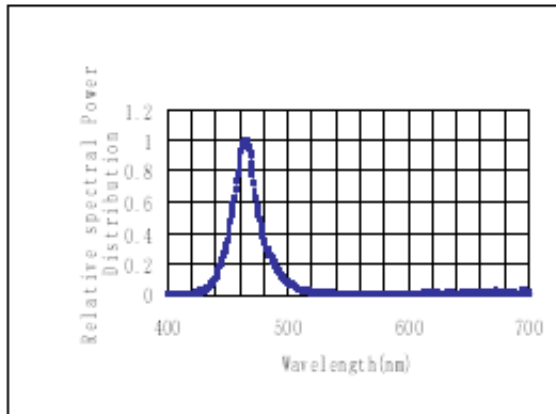
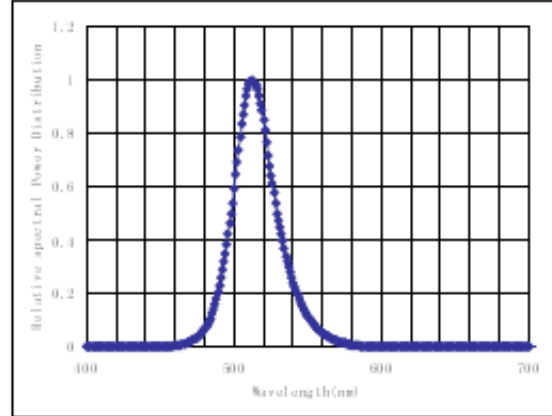
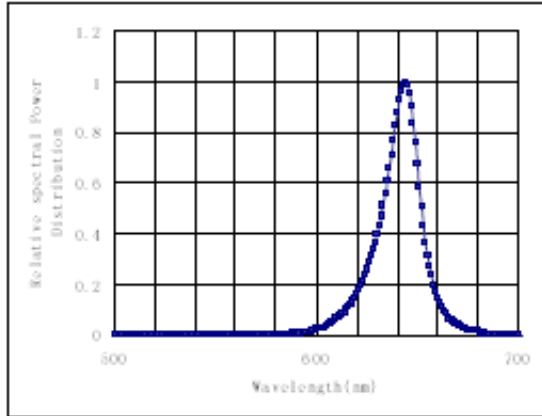

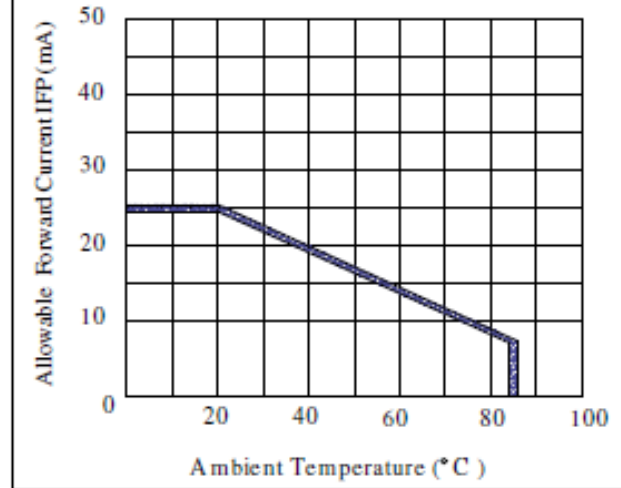
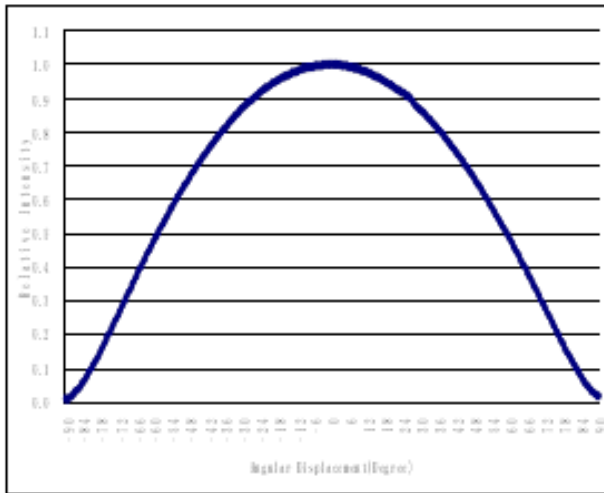

### Dimensions for Tape

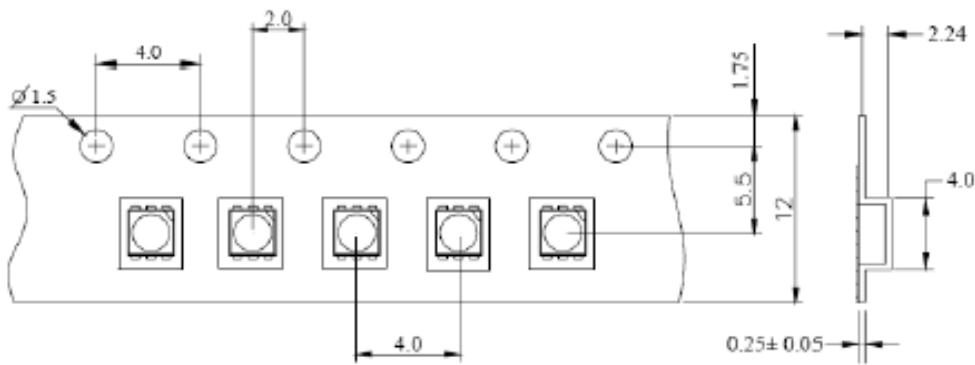

### Dimensions for Reel

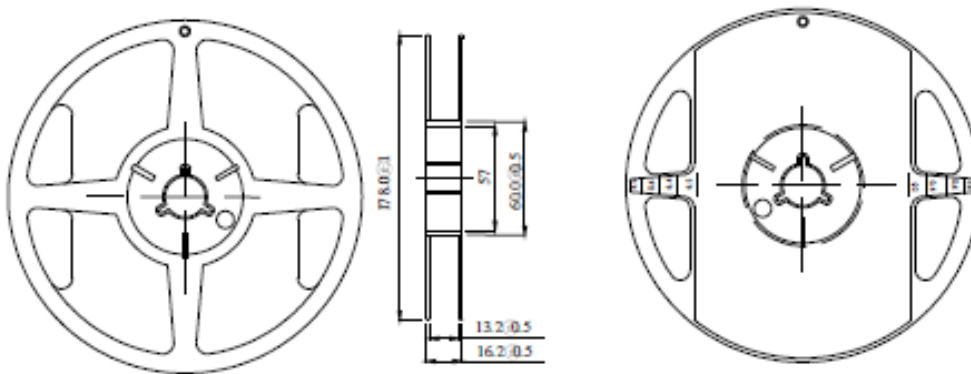

#### Notes:

1. All dimensions are in mm, tolerance is  $\pm 2.0$  mm unless otherwise noted.
2. Specifications are subject to change without notice.

## PRECAUTION IN USE

### Storage

Recommended storage environment

Temperature: 5°C ~ 30°C (41°F ~ 86°F)

Humidity: 60% RH Max.

Use within 7 days after opening of sealed vapor/ESD barrier bags. If the moisture absorbent material (silica gel) has faded away or the LEDs have exceeded the storage time, baking treatment should be performed using the following conditions.

Baking treatment : 60±5°C for 24 hours. Fold the opened bag firmly and keep in dry environment.

### Soldering

	Reflow Soldering		Hand Soldering	
	Lead Solder	Lead – free Solder		
Pre-heat	120~150°C	180~200°C	Temperature	350°C Max.
Pre-heat time	120sec. Max.	120sec. Max.	Soldering time	3sec. Max. (one time only)
Peak temperature	240°C Max.	260°C Max.		
Soldering time	10sec. Max.	10sec. Max.		
Condition	refer to Temperature- profile 1	refer to Temperature- profile 2		

After reflow soldering rapid cooling should be avoided.

[Temperature-profile (Surface of circuit board)] Use the conditions shown to the under figure.

< 1 : Lead Solder >

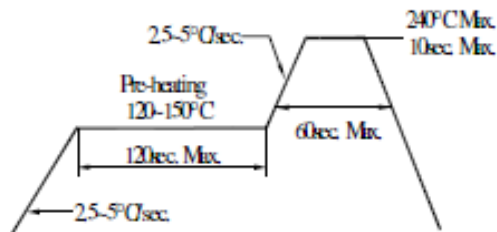

< 2 : Lead-free Solder >

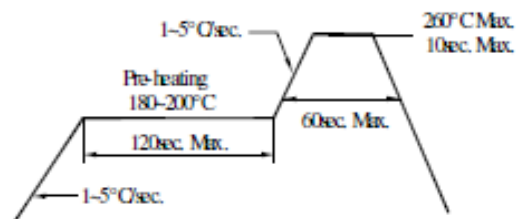

### Cleaning :

The conditions of cleaning after soldering:

An alcohol-based solvent such as Isopropyl Alcohol(IPA) is recommended.

Temperature Time:<50°C \*30sec, or <30°C \*3min

Ultra sonic cleaning:<15W/bath; Bath volume:1liter max.

Curing:100 max,<3min

Cautions of Pick and Place:

It should be avoided to load stress on the resin during high temperature.

Avoid rubbing or scraping the resin by any object.

Electric-static may cause damage to the component. Please confirm that the equipment is grounding well. Using an ionizer fan is recommended.

Cautions of Design and Applications:

It should be done to connect with a current-limiting serial resistor. Avoid to drive reverse voltage over the specifications on LED when ON/OFF. Any application should refer to the specifications of absolute maximum ratings.

The dimensions of the recommended soldering pattern may not meet every user. Please confirm and study first before designing the soldering pattern in order to obtain the best performance of soldering.

Do not contact with any component on the assembly board.

### Static Electricity:

These products are so sensitive to static electricity charge so all equipment and machinery must be properly grounded and it is recommended to use a wristband or anti-electrostatic glove when handling the SMD LED.

Particularly if any over-current and over-voltage which exceed the Absolute

Maximum Ratings of LED applied, the more energy may cause damage or possibly result in electrical destruction of the Products.

A protection design should be installed in the LED driving circuit, which does not exceed the max. rating for surge current during on/off switching.

A tip if soldering iron is requested to be grounded .An ionizer should be installed when risk of static generation is high.

If the countermeasures mentioned above are implemented, LED can work well.

Users are required to check those countermeasures when problems occur by static electricity charge

**Other:**

Damaged SMD LED will show unusual characteristics such as leak current remarkably low current. Increase, turn-on voltage becomes lower and the SMD LED get unlighted at low current.

In automatic mounting of the SMD LEDs on printed circuit boards, any bending and pulling forces or shock against the SMD LEDs shall be kept min. to prevent them from expanding or electrical failures and mechanical damages of the devices.

**Illustration & Application**

The SMD LED taping is much smaller than leaded components, thus enable smaller size, applications, etc. higher packing density, reduced storage space and finally smaller equipment board to be obtained. Besides, lightweight makes them ideal for miniature

The products described in this brochure are intended only for standard applications or general electronic equipment such as :

1. Telecommunication: indicator and backlight in telephone and fax.
2. Automotive: backlight in dashboard and switch.
3. LCD: Flat backlight for LCD, switch and symbol.