

Top View of Assembly

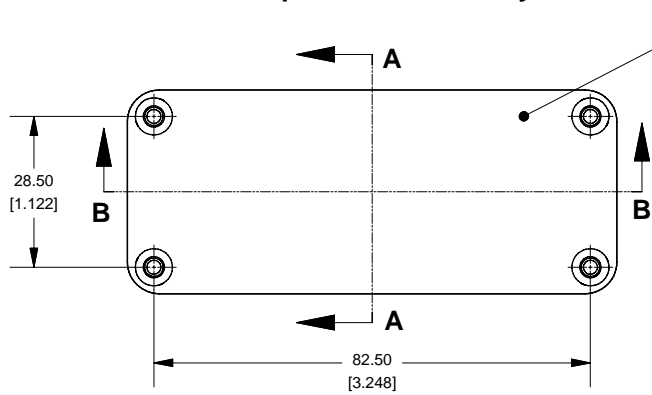

SECTION A-A  
End View of Assembly

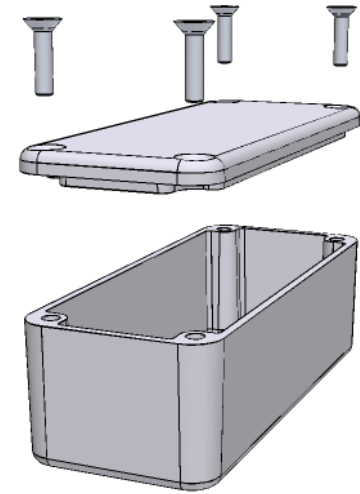
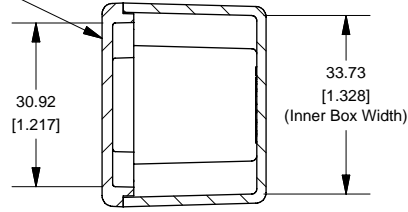

SECTION B-B  
Side View of Assembly

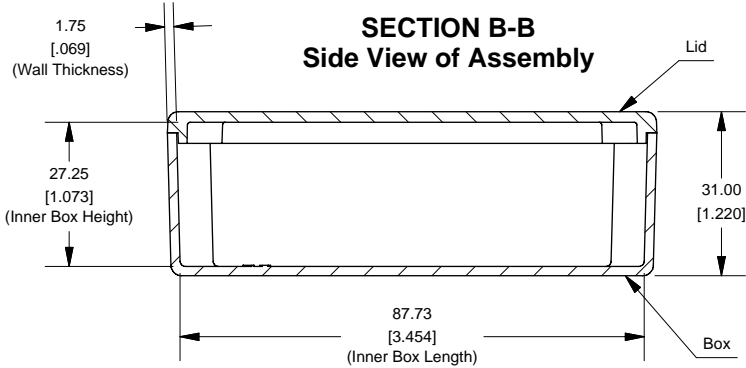

Top View Looking Inside Box

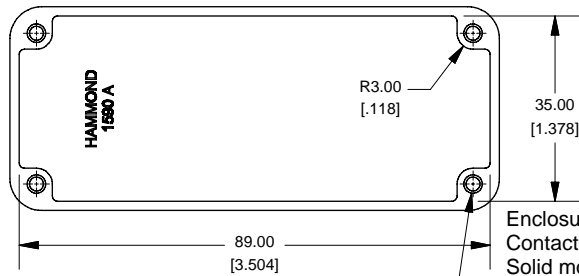

Enclosures can be Factory Modified (Milling, Drilling, Printing etc.)  
Contact Factory [mjm@hammondmfg.com](mailto:mjm@hammondmfg.com) for quotes  
Solid models of this enclosure available in STEP or IGES.

6-32 UNC - 2B  $\nabla$  10.00  
 $\perp$   $\varnothing$ 3.50  $\nabla$  3.00  
(Threaded Holes)

Lid

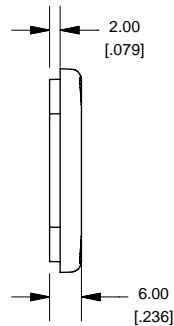
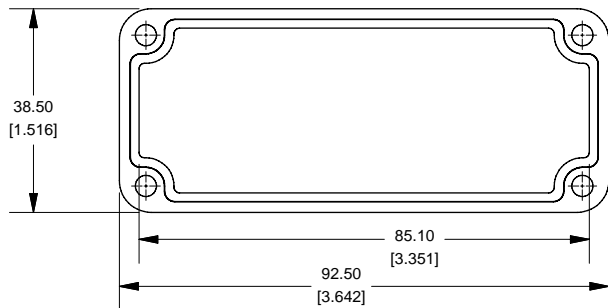

**NOTE**

Purchased assembly includes box, lid and 4 cover screws.  
Box and lid are made from Diecast Aluminum Alloy (alloy type 380).  
Silicone Gasket Loctite #5950

**PART NUMBERS**

1590A Enclosure	
Unfinished	1590A
Grey Textured Polyester Powder Paint - RAL 7038	1590AGY
Black Textured Polyester Powder Paint - RAL 9011	1590ABK
1590A Liquid Resistant Enclosure (Silicon Factory Installed Gasket)	
Unfinished	1590WA
Black Textured Powder Paint	1590WABK
ACCESSORIES	
Recommended Torque: 75 ozf.in / 55 cN.m	
Black Textured Cover Screws (Pkg 50) [6-32 x 1/2" SS Type 304]	1590WMS100BK
Unfinished Cover Screws (Pkg 100) [6-32 x 1/2" Nickel Plated Screws]	1590WMS100
Standard Cover Screws	
Unfinished Cover Screws (Pkg 100) [6-32 x 1/2" Nickel Plated Screws]	1590MS100
Black Textured Cover Screws (Pkg 50) [6-32 x 1/2" SS Type 304]	1590MS100BK

**HAMMOND MANUFACTURING™**  
1590A  
[www.hammondmfg.com](http://www.hammondmfg.com)

### Top View of Assembly

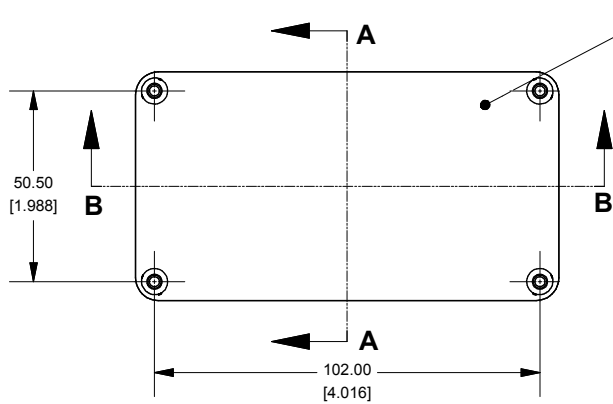

### SECTION A-A End View of Assembly

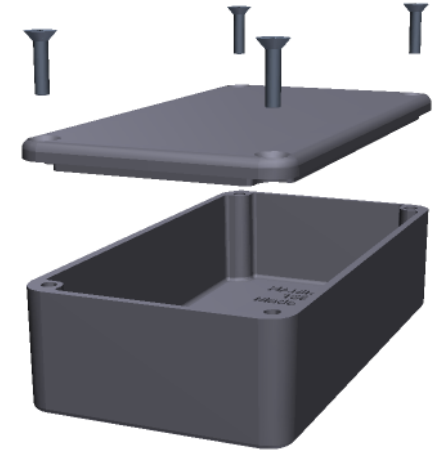
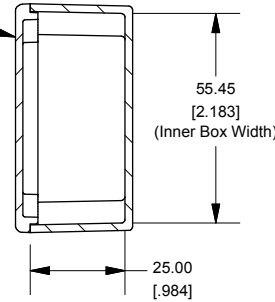

### SECTION B-B Side View of Assembly

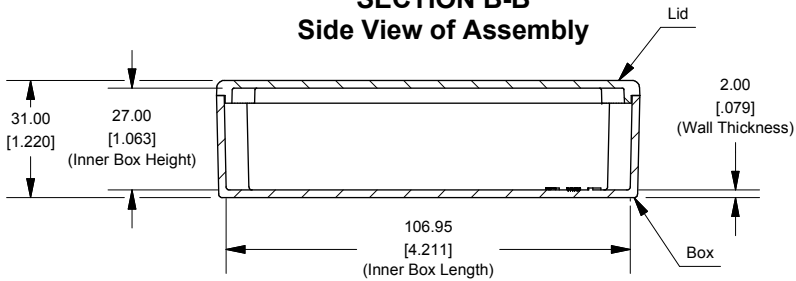

### Top View Looking Inside Box

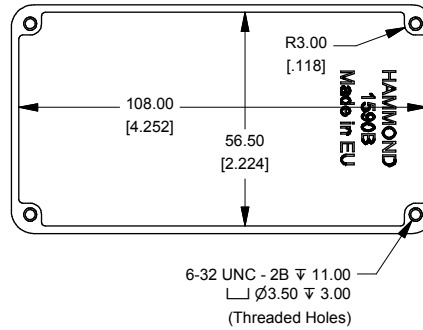

Enclosures can be Factory Modified ( Milling, Drilling, Printing etc.)  
 Contact Factory [mjm@hammondmfg.com](mailto:mjm@hammondmfg.com) for quotes  
 Solid models of this enclosure available in STEP or IGES.

### Lid

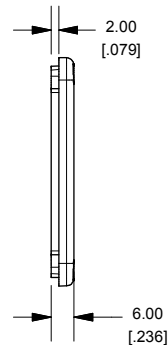
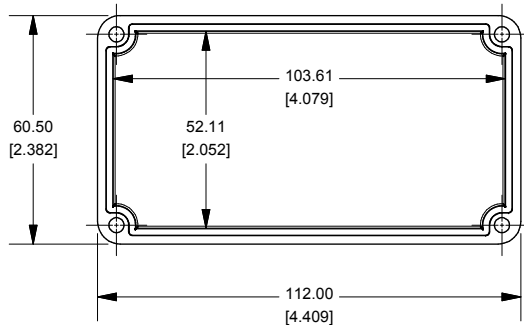

NOTE	
Purchased assembly includes box, lid and 4 cover screws. Box and lid are made from Diecast Aluminum Alloy (alloy type 380). Silicone Gasket Loctite #5950	
PART NUMBERS	
1590B Enclosure	
Unfinished	1590B
Grey Textured Polyester Powder Paint - RAL 7038	1590BGY
Black Textured Polyester Powder Paint - RAL 9011	1590BBK
1590B Liquid Resistant Enclosure (Silicon Factory Installed Gasket)	
Unfinished	1590WB
Black Textured Powder Paint	1590WBBK
ACCESSORIES	
Recommended Torque: 75 ozf.in / 55 cN.m	
Black Textured Cover Screws (Pkg 100) [6-32 x 1/2" SS Type 304]	1590WMS100BK
Unfinished Cover Screws (Pkg 100) [6-32 x 1/2" SS Type 304]	1590WMS100
Standard Cover Screws	
Unfinished Cover Screws (Pkg 100) [6-32 x 1/2" Nickel Plated Screws]	1590MS100
Black Textured Cover Screws (Pkg 50) [6-32 x 1/2" Nickel Plated Screws]	1590MS50BK



### Top View of Assembly

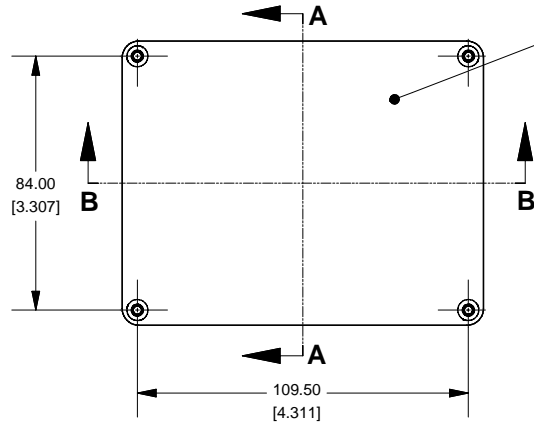

### SECTION A-A End View of Assembly

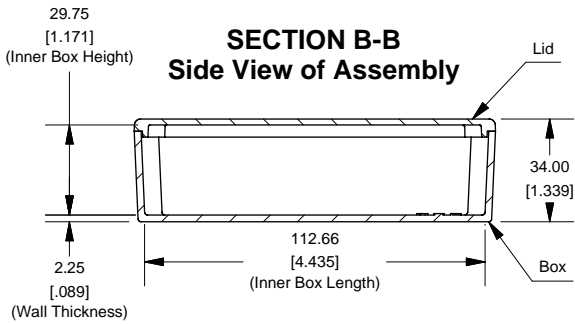
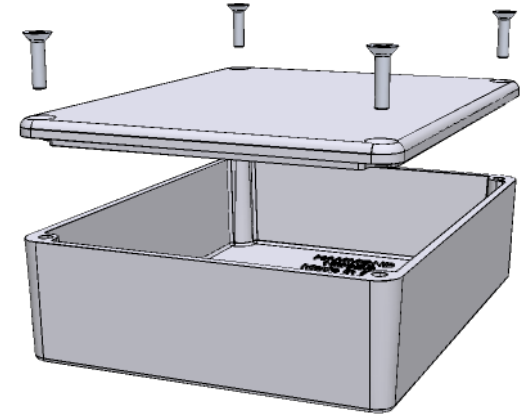
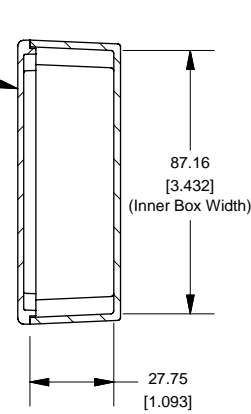

### SECTION B-B Side View of Assembly

### Lid

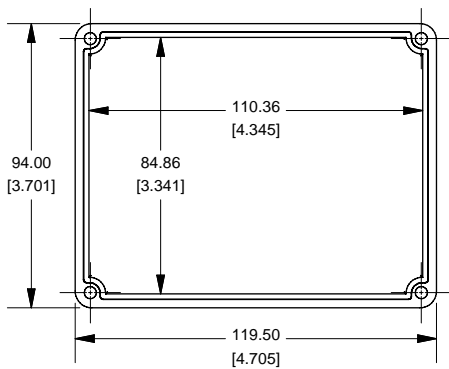

### Top View Looking Inside Box

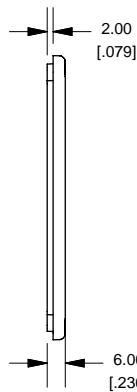
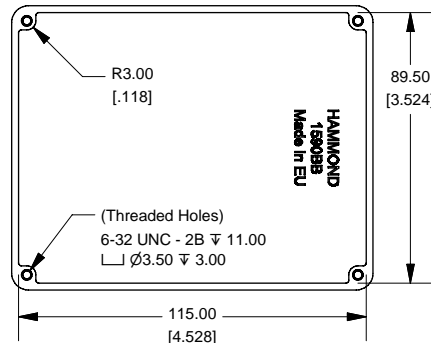

Enclosures can be Factory Modified ( Milling, Drilling, Printing etc.)  
Contact Factory [mjm@hammondmfg.com](mailto:mjm@hammondmfg.com) for quotes  
Solid models of this enclosure available in STEP or IGES.

NOTE	
Purchased assembly includes box, lid and 4 cover screws. Box and lid are made from Diecast Aluminum Alloy (alloy type 380). Silicone Gasket Loctite #5950	
PART NUMBERS	
1590BB Enclosure	
Unfinished	1590BB
Grey Textured Polyester Powder Paint - RAL 7038	1590BBGY
Black Textured Polyester Powder Paint - RAL 9011	1590BBBK
1590BB Liquid Resistant Enclosure (Silicon Factory Installed Gasket)	
Unfinished	1590WBB
Black Textured Powder Paint	1590WBBBK
ACCESSORIES	
Recommended Torque: 75 ozf.in / 55 cN.m	
Black Textured Cover Screws (Pkg 50) [6-32 x 1/2" SS Type 304]	1590WMS100BK
Unfinished Cover Screws (Pkg 100) [6-32 x 1/2" Nickel Plated Screws]	1590WMS100
Standard Cover Screws	
Unfinished Cover Screws (Pkg 100) [6-32 x 1/2" Nickel Plated Screws]	1590MS100
Black Textured Cover Screws (Pkg 50) [6-32 x 1/2" SS Type 304]	1590MS100BK

**HAMMOND  
MANUFACTURING™**

**1590BB**

[www.hammondmfg.com](http://www.hammondmfg.com)

### Top View of Assembly

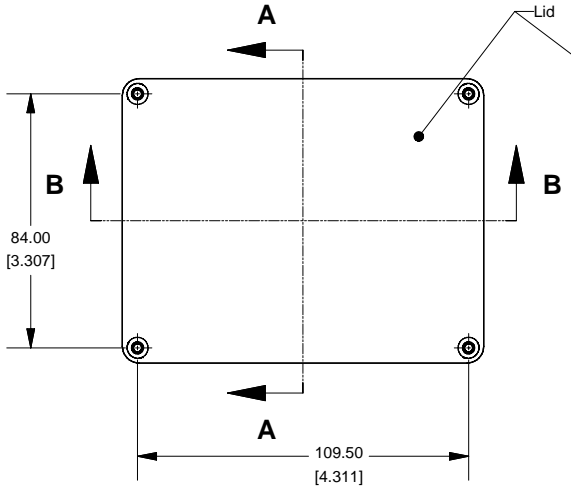

### SECTION A-A End View of Assembly

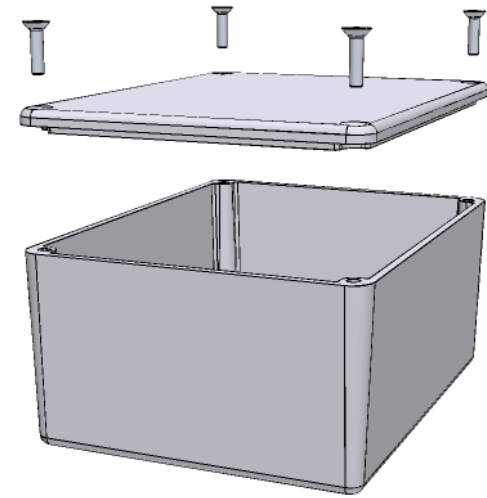
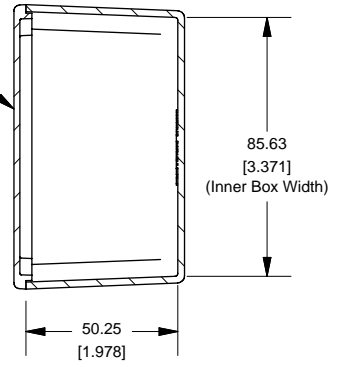

### Top View Looking Inside Box

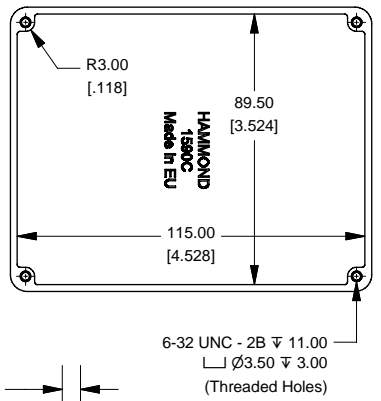

### SECTION B-B Side View of Assembly

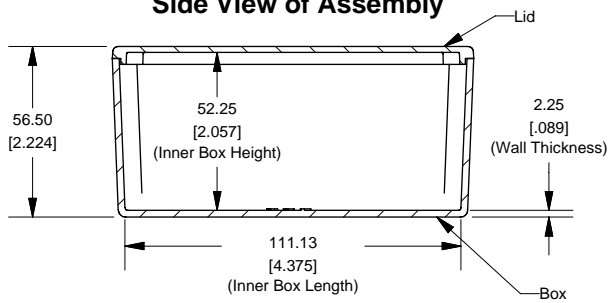

### Lid

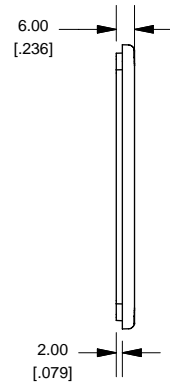
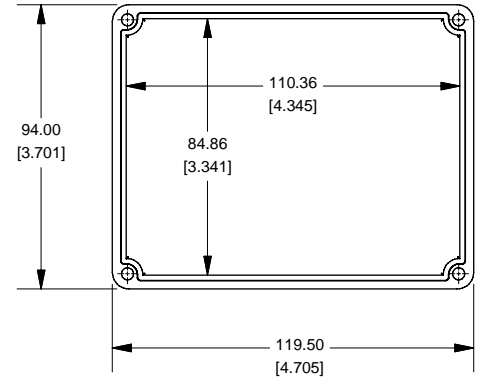

Enclosures can be Factory Modified ( Milling, Drilling, Printing etc.)  
 Contact Factory [mjm@hammondmfg.com](mailto:mjm@hammondmfg.com) for quotes  
 Solid models of this enclosure available in STEP or IGES.

NOTE	
Purchased assembly includes box, lid and 4 cover screws.	
Box and lid are made from Diecast Aluminum Alloy (alloy type 380).	
Silicone Gasket Loctite #5950	
PART NUMBERS	
1590C Enclosure	
Unfinished	1590C
Grey Textured Polyester Powder Paint - RAL 7038	1590CGY
Black Textured Polyester Powder Paint - RAL 9011	1590CBK
1590C Liquid Resistant Enclosure (Silicon Factory Installed Gasket)	
Unfinished	1590WC
Black Textured Powder Paint	1590WCBK
ACCESSORIES	
Recommended Torque: 75 ozf.in / 55 cN.m	
Black Textured Cover Screws (Pkg 50) [6-32 x 1/2" SS Type 304]	1590WMS100BK
Unfinished Cover Screws (Pkg 100) [6-32 x 1/2" Nickel Plated Screws]	1590WMS100
Standard Cover Screws	
Unfinished Cover Screws (Pkg 100) [6-32 x 1/2" Nickel Plated Screws]	1590MS100
Black Textured Cover Screws (Pkg 50) [6-32 x 1/2" SS Type 304]	1590MS100BK



**Top View of Assembly**

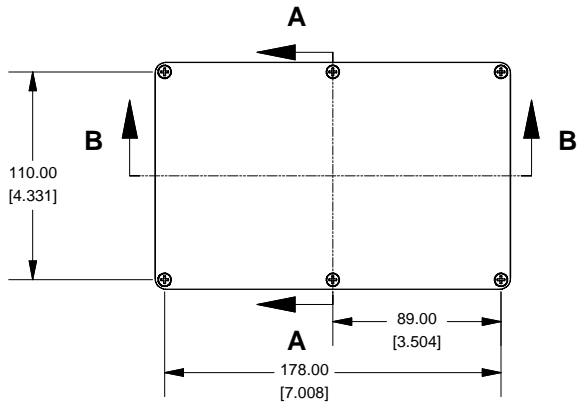

**SECTION A-A  
End View of Assembly**

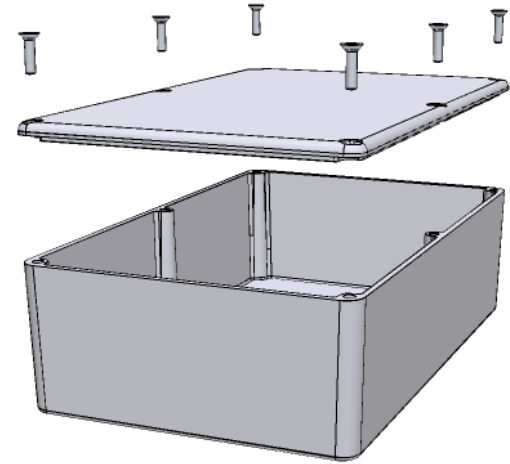
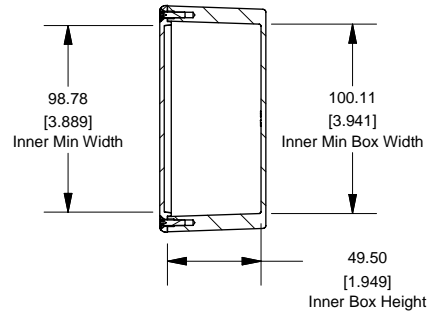

**SECTION B-B  
Side View of Assembly**

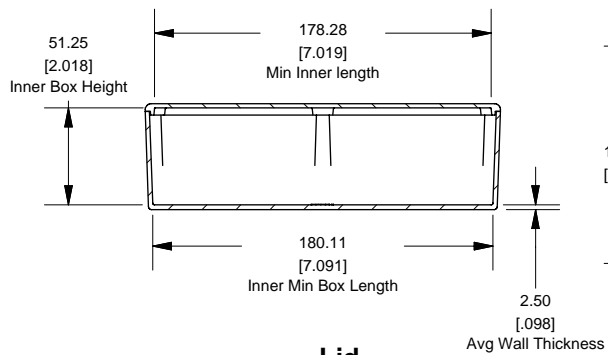

**Lid**

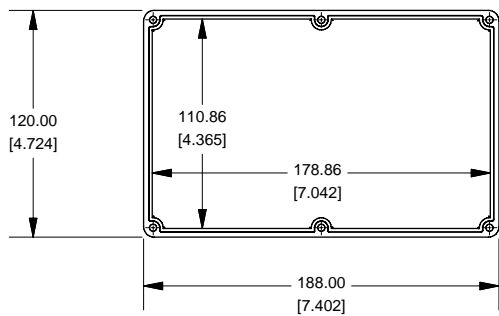

**Top View Looking Inside Box**

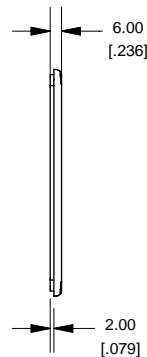
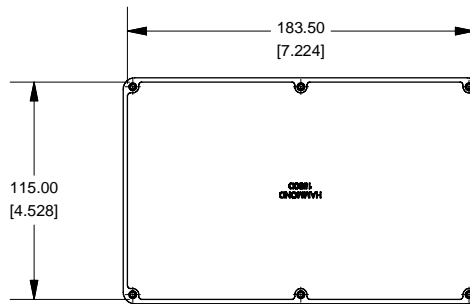

Enclosures can be Factory Modified ( Milling, Drilling, Printing etc.)  
Contact Factory [mjm@hammondmfg.com](mailto:mjm@hammondmfg.com) for quotes  
Solid models of this enclosure available in STEP or IGES.

NOTE	
Purchased assembly includes box, lid and 6 cover screws. Box and lid are made from Diecast Aluminum Alloy (alloy type 380). Silicone Gasket Loctite #5950	
PART NUMBERS	
1590D Enclosure	
Unfinished	1590D
Grey Textured Polyester Powder Paint - RAL 7038	1590DGY
Black Textured Polyester Powder Paint - RAL 9011	1590DBK
1590D Liquid Resistant Enclosure (Silicon Factory Installed Gasket)	
Unfinished	1590WD
Black Textured Powder Paint	1590WDBK
ACCESSORIES	
Recommended Torque: 75 ozf.in / 55 cN.m	
Black Textured Cover Screws (Pkg 50) [6-32 x 1/2" SS Type 304]	1590WMS100BK
Unfinished Cover Screws (Pkg 100) [6-32 x 1/2" Nickel Plated Screws]	1590WMS100
Standard Cover Screws	
Unfinished Cover Screws (Pkg 100) [6-32 x 1/2" Nickel Plated Screws]	1590MS100
Black Textured Cover Screws (Pkg 50) [6-32 x 1/2" SS Type 304]	1590MS100BK



### Top View of Assembly

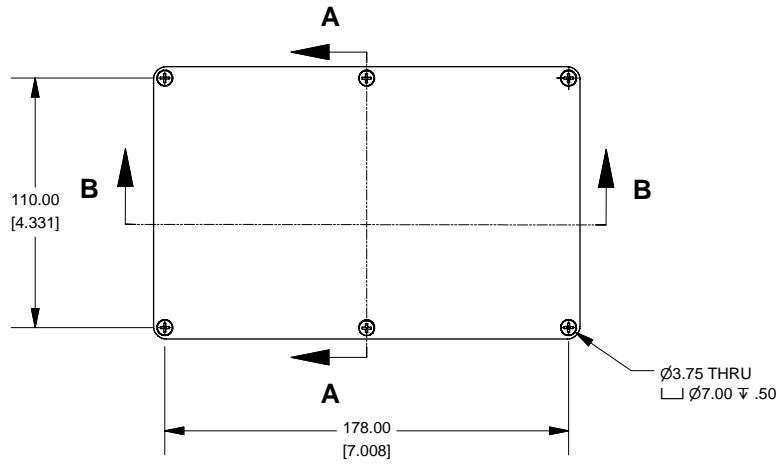

### SECTION A-A End View of Assembly

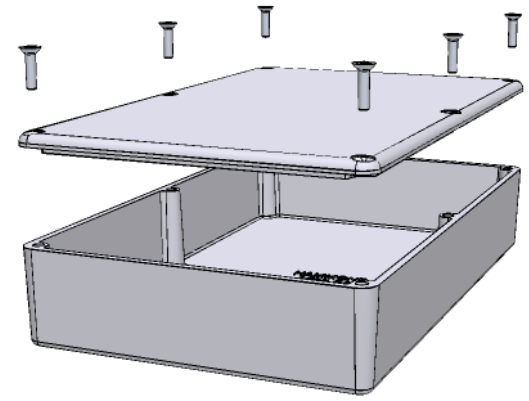
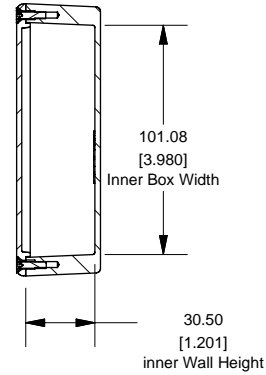

### Top View Looking Inside Box

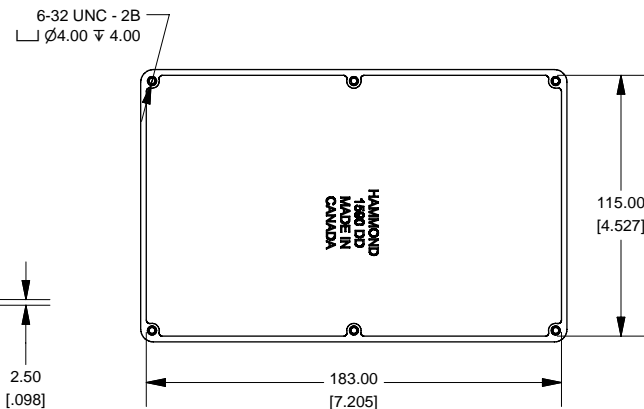

### SECTION B-B Side View of Assembly

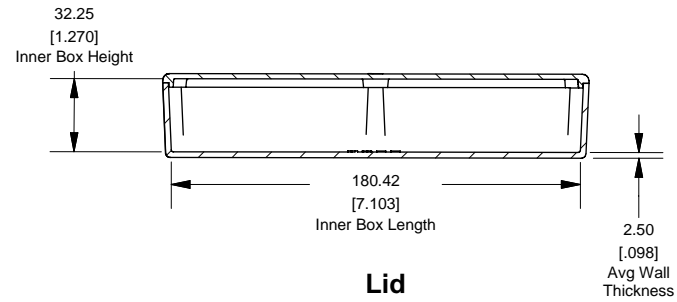

### Lid

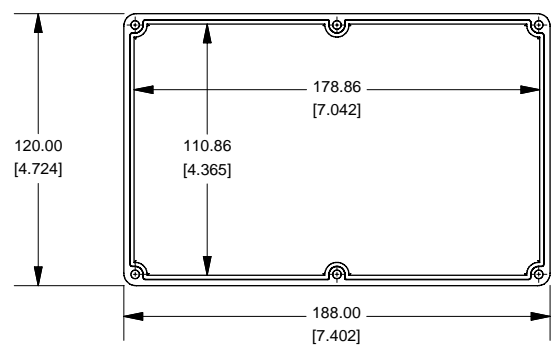

Enclosures can be Factory Modified ( Milling, Drilling, Printing etc.)  
Contact Factory [mjm@hammondmfg.com](mailto:mjm@hammondmfg.com) for quotes  
Solid models of this enclosure available in STEP or IGES.

NOTE	
Purchased assembly includes box, lid and 6 cover screws. Box and lid are made from Diecast Aluminum Alloy (alloy type 380). Silicone Gasket Loctite #5950	
PART NUMBERS	
1590DD Enclosure	
Unfinished	1590DD
Grey Textured Polyester Powder Paint - RAL 7038	1590DDGY
Black Textured Polyester Powder Paint - RAL 9011	1590DBK
1590DD Liquid Resistant Enclosure (Silicon Factory Installed Gasket)	
Unfinished	1590WDD
Black Textured Powder Paint	1590WDBK
ACCESSORIES	
Recommended Torque: 75 ozf.in / 55 cN.m	
Black Textured Cover Screws (Pkg 50) [6-32 x 1/2" SS Type 304]	1590WMS100BK
Unfinished Cover Screws (Pkg 100) [6-32 x 1/2" Nickel Plated Screws]	1590WMS100
Standard Cover Screws	
Unfinished Cover Screws (Pkg 100) [6-32 x 1/2" Nickel Plated Screws]	1590MS100
Black Textured Cover Screws (Pkg 50) [6-32 x 1/2" SS Type 304]	1590MS100BK

**HAMMOND MANUFACTURING™**  
1590DD  
[www.hammondmfg.com](http://www.hammondmfg.com)

### Top View of Assembly

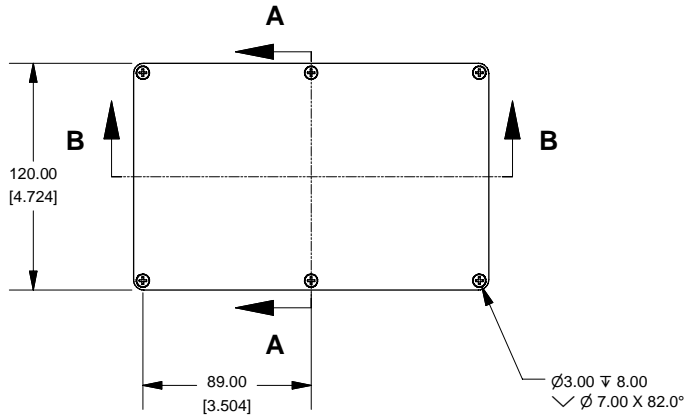

### SECTION A-A End View of Assembly

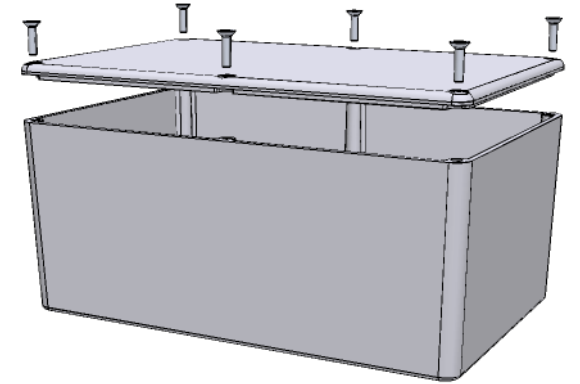
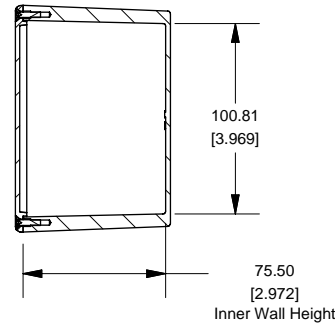

### SECTION B-B Side View of Assembly

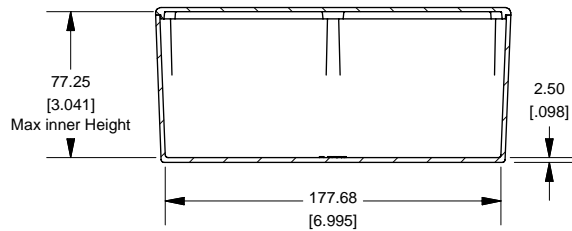

### Top View Looking Inside Box

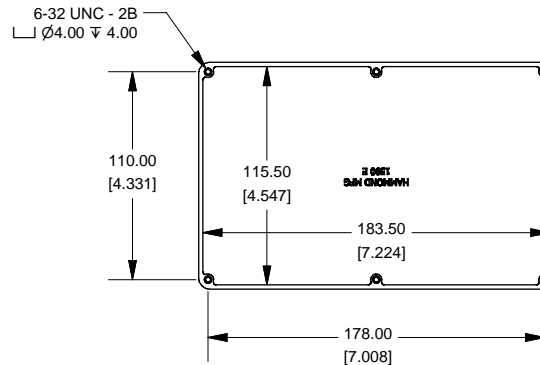

### Lid

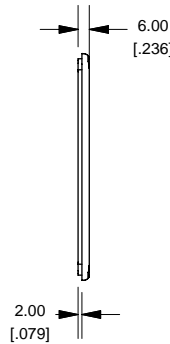
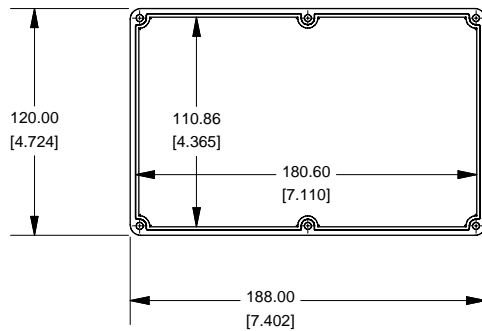

Enclosures can be Factory Modified ( Milling, Drilling, Printing etc.)  
Contact Factory [mjm@hammondmfg.com](mailto:mjm@hammondmfg.com) for quotes  
Solid models of this enclosure available in STEP or IGES.

NOTE	
Purchased assembly includes box, lid and 6 cover screws. Box and lid are made from Diecast Aluminum Alloy (alloy type 380). Silicone Gasket Loctite #5950	
PART NUMBERS	
1590E Enclosure	
Unfinished	1590E
Grey Textured Polyester Powder Paint - RAL 7038	1590EGY
Black Textured Polyester Powder Paint - RAL 9011	1590EBK
1590E Liquid Resistant Enclosure (Silicon Factory Installed Gasket)	
Unfinished	1590WE
Black Textured Powder Paint	1590WEBK
ACCESSORIES	
Recommended Torque: 75 ozf.in / 55 cN.m	
Black Textured Cover Screws (Pkg 50) [6-32 x 1/2" SS Type 304]	1590WMS100BK
Unfinished Cover Screws (Pkg 100) [6-32 x 1/2" Nickel Plated Screws]	1590WMS100
Standard Cover Screws	
Unfinished Cover Screws (Pkg 100) [6-32 x 1/2" Nickel Plated Screws]	1590MS100
Black Textured Cover Screws (Pkg 50) [6-32 x 1/2" SS Type 304]	1590MS100BK



**Top View of Assembly**

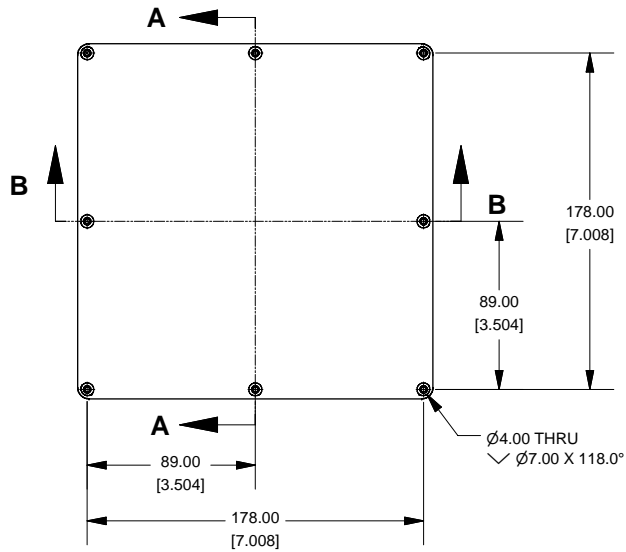

**SECTION A-A  
End View of Assembly**

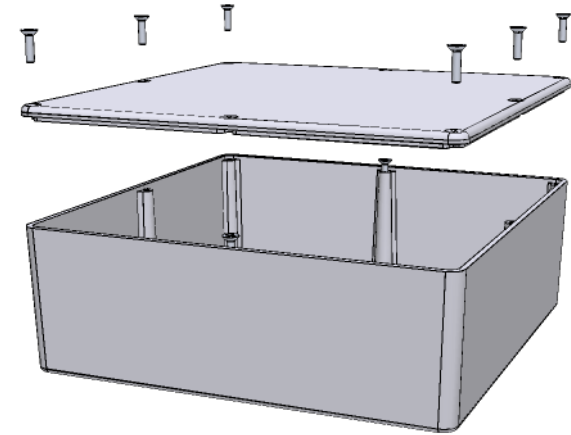
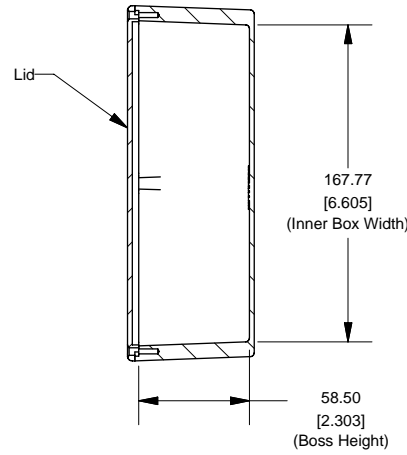

**Top View Looking Inside Box**

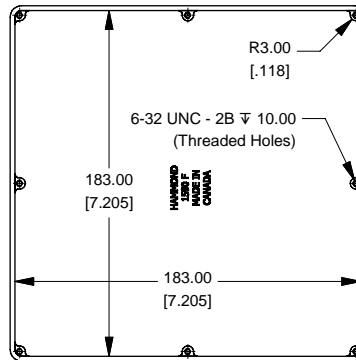

**SECTION B-B  
Side View of Assembly**

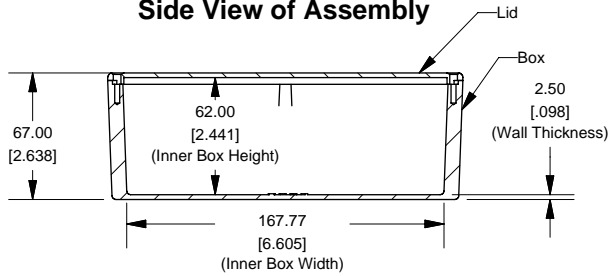

**Lid**

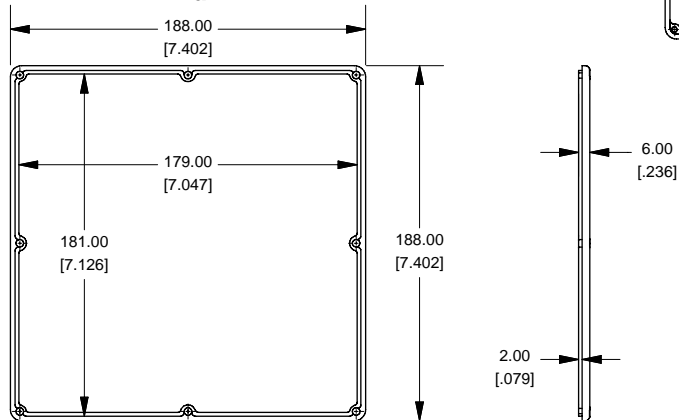

Enclosures can be Factory Modified ( Milling, Drilling, Printing etc.)  
Contact Factory [mjm@hammondmfg.com](mailto:mjm@hammondmfg.com) for quotes  
Solid models of this enclosure available in STEP or IGES.

**NOTE**

Purchased assembly includes box, lid and 6 cover screws.  
Box and lid are made from Diecast Aluminum Alloy (alloy type 380).  
Silicone Gasket Loctite #5950

**PART NUMBERS**

1590F Enclosure	
Unfinished	1590F
Grey Textured Polyester Powder Paint - RAL 7038	1590FGY
Black Textured Polyester Powder Paint - RAL 9011	1590FBK
1590F Liquid Resistant Enclosure (Silicon Factory Installed Gasket)	
Unfinished	1590WF
Black Textured Powder Paint	1590WFBK
ACCESSORIES	
Recommended Torque: 75 ozf.in / 55 cN.m	
Black Textured Cover Screws (Pkg 50) [6-32 x 1/2" SS Type 304]	1590WMS100BK
Unfinished Cover Screws (Pkg 100) [6-32 x 1/2" Nickel Plated Screws]	1590WMS100
Standard Cover Screws	
Unfinished Cover Screws (Pkg 100) [6-32 x 1/2" Nickel Plated Screws]	1590MS100
Black Textured Cover Screws (Pkg 50) [6-32 x 1/2" SS Type 304]	1590MS100BK

**HAMMOND  
MANUFACTURING™**

**1590F**

[www.hammondmfg.com](http://www.hammondmfg.com)



### Top View of Assembly

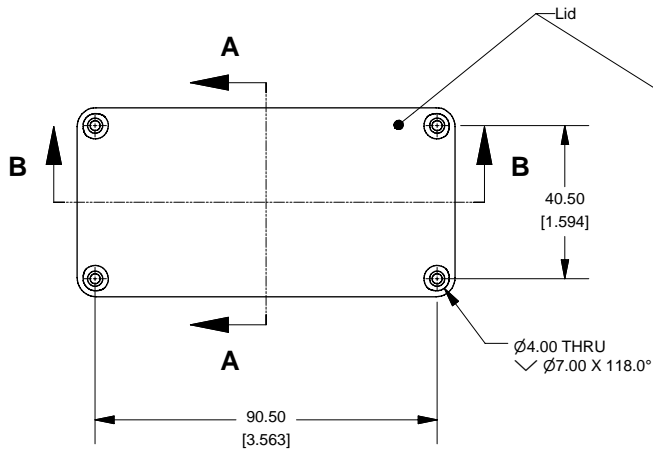

### SECTION A-A End View of Assembly

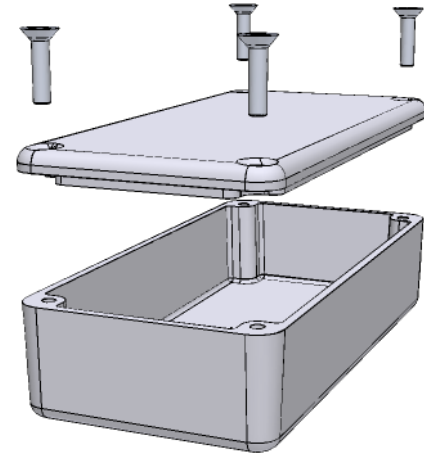
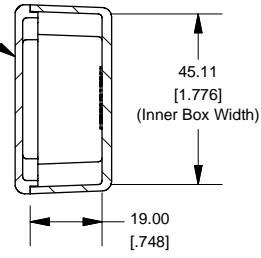

### SECTION B-B Side View of Assembly

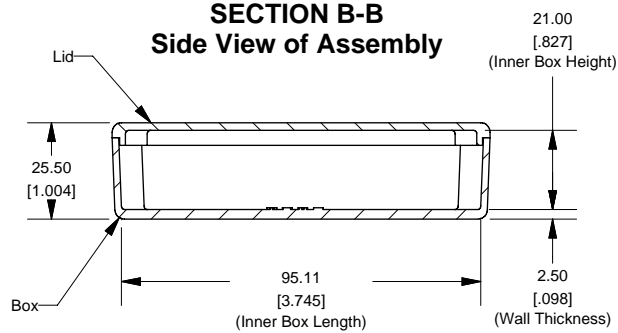

### Top View Looking Inside Box

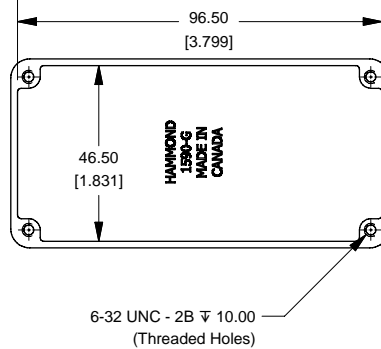

### Lid

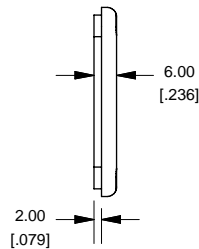
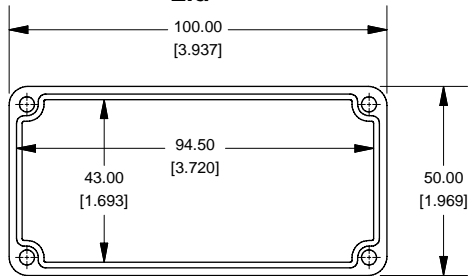

Enclosures can be Factory Modified ( Milling, Drilling, Printing etc.)  
 Contact Factory [mjm@hammondmfg.com](mailto:mjm@hammondmfg.com) for quotes  
 Solid models of this enclosure available in STEP or IGES.

NOTE	
Purchased assembly includes box, lid and 4 cover screws. Box and lid are made from Diecast Aluminum Alloy (alloy type 380). Silicone Gasket Loctite #5950	
PART NUMBERS	
1590G Enclosure	
Unfinished	1590G
Grey Textured Polyester Powder Paint - RAL 7038	1590GGY
Black Textured Polyester Powder Paint - RAL 9011	1590GBK
1590G Liquid Resistant Enclosure (Silicon Factory Installed Gasket)	
Unfinished	1590WG
Black Textured Powder Paint	1590WGBK
ACCESSORIES	
Recommended Torque: 75 ozf.in / 55 cN.m	
Black Textured Cover Screws (Pkg 50) [6-32 x 1/2" SS Type 304]	1590WMS100BK
Unfinished Cover Screws (Pkg 100) [6-32 x 1/2" Nickel Plated Screws]	1590WMS100
Standard Cover Screws	
Unfinished Cover Screws (Pkg 100) [6-32 x 1/2" Nickel Plated Screws]	1590MS100
Black Textured Cover Screws (Pkg 50) [6-32 x 1/2" SS Type 304]	1590MS100BK

**HAMMOND MANUFACTURING™**  
 1590G  
[www.hammondmfg.com](http://www.hammondmfg.com)

### Top View of Assembly

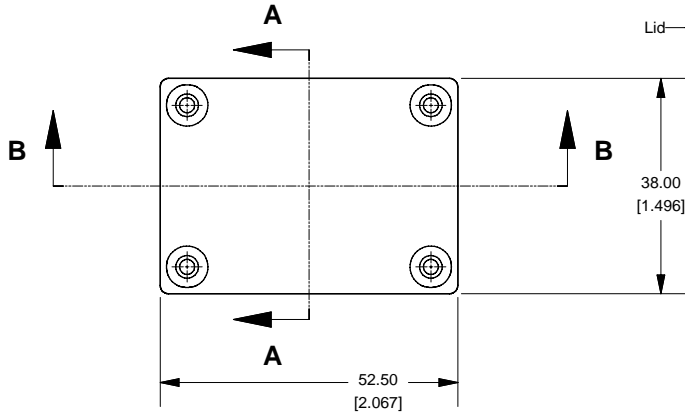

### SECTION A-A End View of Assembly

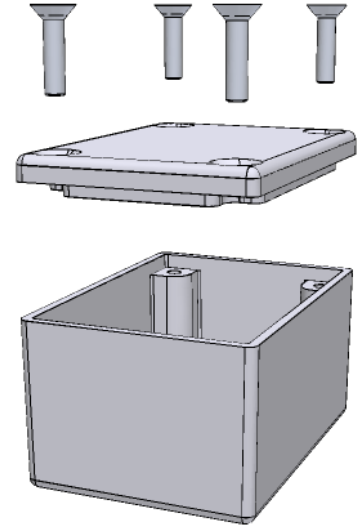
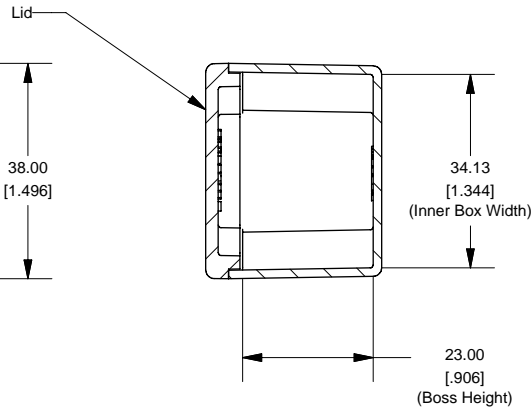

### SECTION B-B Side View of Assembly

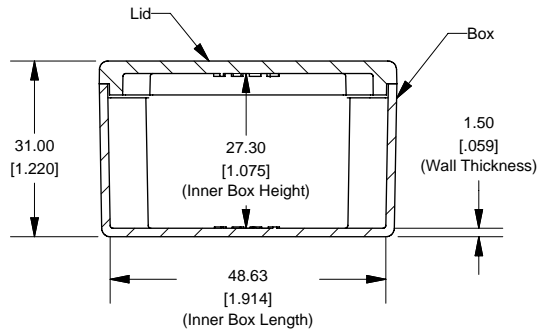

### Top View Looking Inside Box

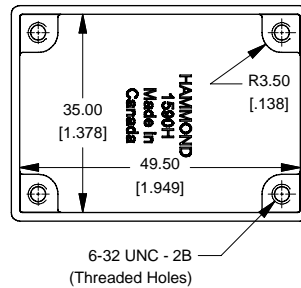

Enclosures can be Factory Modified ( Milling, Drilling, Printing etc.)  
 Contact Factory [mjm@hammondmfg.com](mailto:mjm@hammondmfg.com) for quotes  
 Solid models of this enclosure available in STEP or IGES.

#### NOTE

Purchased assembly includes box, lid and 4 cover screws.  
 Box and lid are made from Diecast Aluminum Alloy (alloy type 380).  
 Silicone Gasket Loctite #5950

#### PART NUMBERS

1590H Enclosure	
Unfinished	1590H
Grey Textured Polyester Powder Paint - RAL 7038	1590HGY
Black Textured Polyester Powder Paint - RAL 9011	1590HBK
1590H Liquid Resistant Enclosure (Silicon Factory Installed Gasket)	
Unfinished	1590WH
Black Textured Powder Paint	1590WHBK

#### ACCESSORIES

Recommended Torque: 75 ozf.in / 55 cN.m	
Black Textured Cover Screws (Pkg 50) [6-32 x 1/2" SS Type 304]	1590WMS100BK
Unfinished Cover Screws (Pkg 100) [6-32 x 1/2" Nickel Plated Screws]	1590WMS100
Standard Cover Screws	
Unfinished Cover Screws (Pkg 100) [6-32 x 1/2" Nickel Plated Screws]	1590MS100
Black Textured Cover Screws (Pkg 50) [6-32 x 1/2" SS Type 304]	1590MS100BK

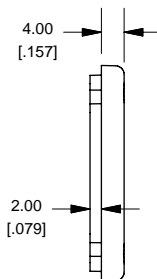
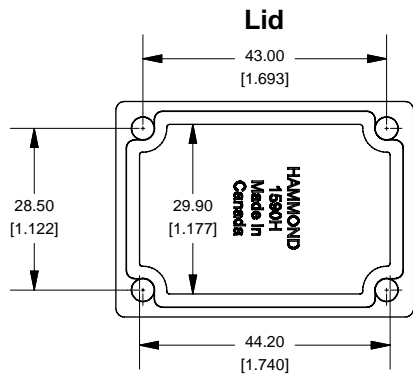

**HAMMOND  
MANUFACTURING™**

1590H

[www.hammondmfg.com](http://www.hammondmfg.com)

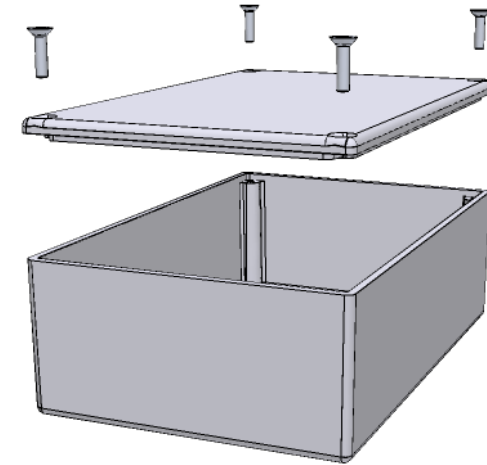
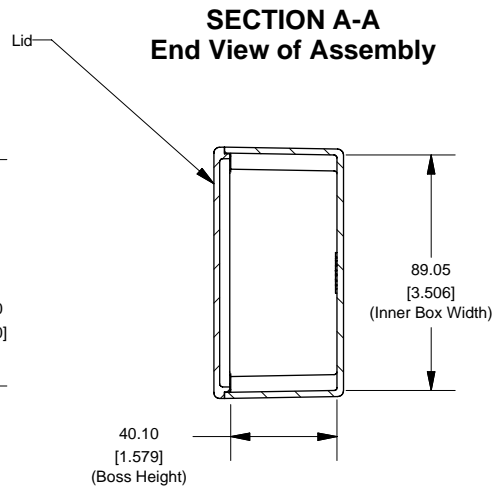
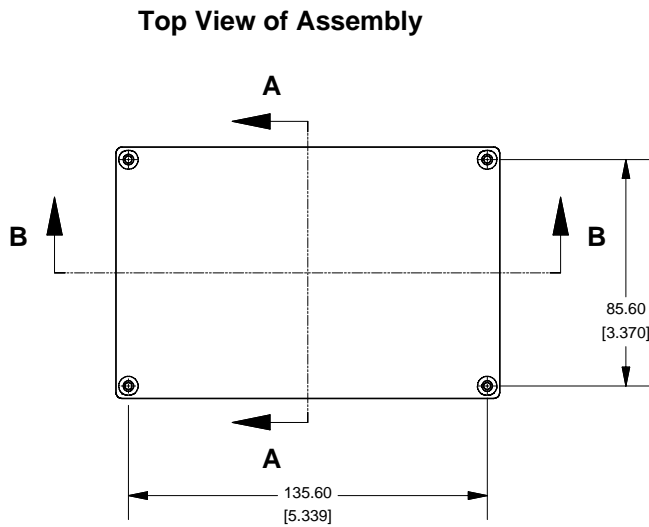

**Top View Looking Inside Box**

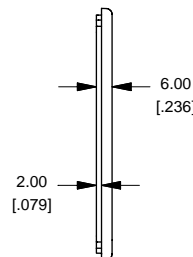
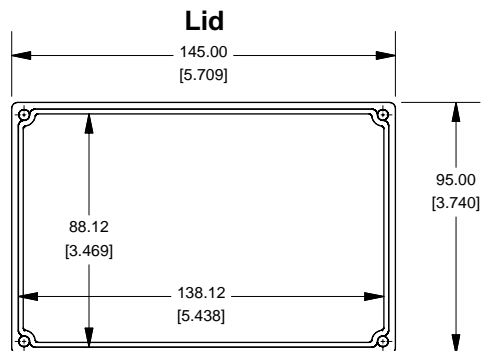
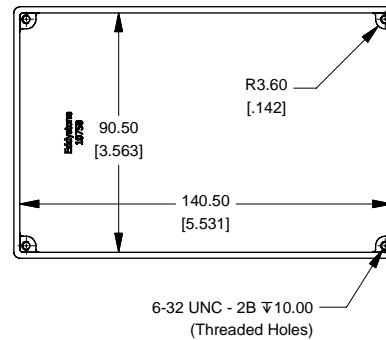
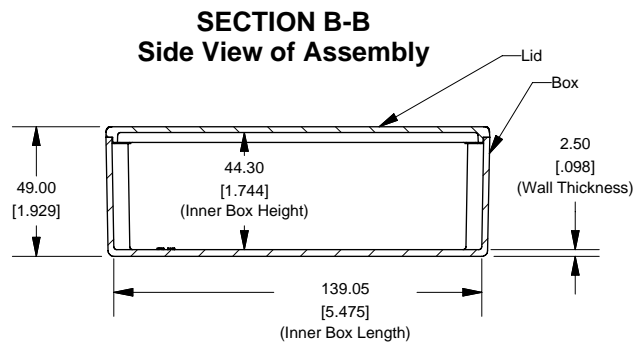

Enclosures can be Factory Modified ( Milling, Drilling, Printing etc.)  
Contact Factory [mjm@hammondmfg.com](mailto:mjm@hammondmfg.com) for quotes  
Solid models of this enclosure available in STEP or IGES.

<b>NOTE</b>	
Purchased assembly includes box, lid and 4 cover screws. Box and lid are made from Diecast Aluminum Alloy (alloy type 380). Silicone Gasket Loctite #5950	
<b>PART NUMBERS</b>	
<b>1590J Enclosure</b>	
<b>Unfinished</b>	1590J
<b>Grey Textured Polyester Powder Paint - RAL 7038</b>	1590JGY
<b>Black Textured Polyester Powder Paint - RAL 9011</b>	1590JBK
<b>1590J Liquid Resistant Enclosure (Silicon Factory Installed Gasket)</b>	
<b>Unfinished</b>	1590WJ
<b>Black Textured Powder Paint</b>	1590WJBK
<b>ACCESSORIES</b>	
<b>Recommended Torque: 75 ozf.in / 55 cN.m</b>	
<b>Black Textured Cover Screws (Pkg 50) [6-32 x 1/2" SS Type 304]</b>	1590WMS100BK
<b>Unfinished Cover Screws (Pkg 100) [6-32 x 1/2" Nickel Plated Screws]</b>	1590WMS100
<b>Standard Cover Screws</b>	
<b>Unfinished Cover Screws (Pkg 100) [6-32 x 1/2" Nickel Plated Screws]</b>	1590MS100
<b>Black Textured Cover Screws (Pkg 50) [6-32 x 1/2" SS Type 304]</b>	1590MS100BK



**Top View of Assembly**

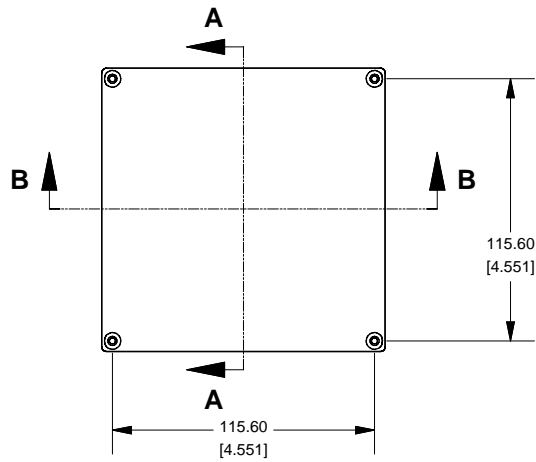

**SECTION A-A  
End View of Assembly**

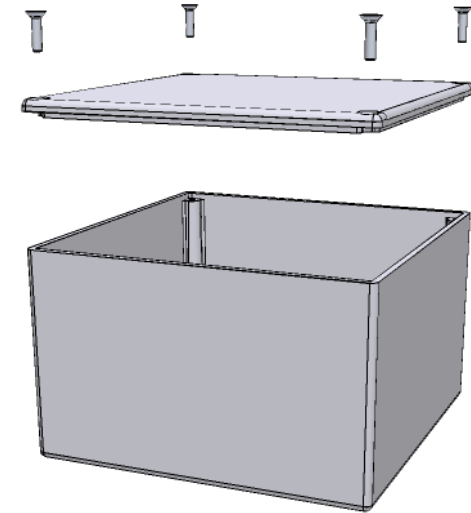
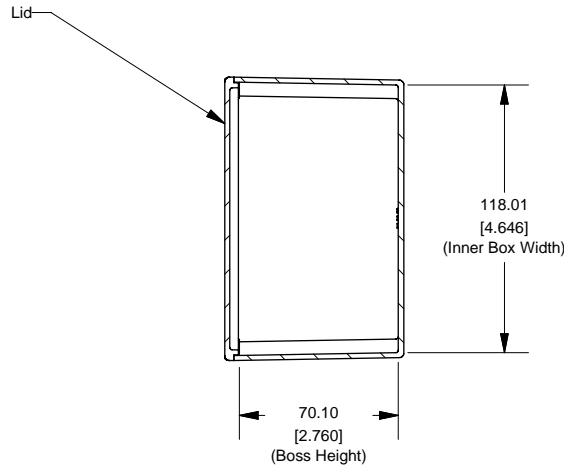

**SECTION B-B  
Side View of Assembly**

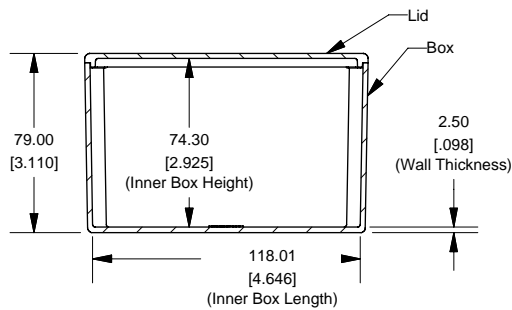

**Top View Looking Inside Box**

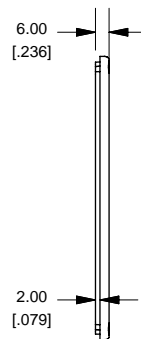
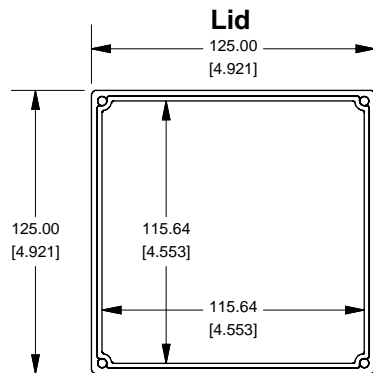
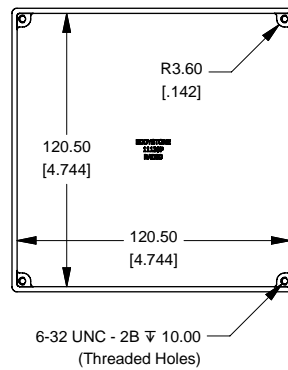

Enclosures can be Factory Modified ( Milling, Drilling, Printing etc.)  
Contact Factory [mjm@hammondmg.com](mailto:mjm@hammondmg.com) for quotes  
Solid models of this enclosure available in STEP or IGES.

NOTE	
Purchased assembly includes box, lid and 4 cover screws. Box and lid are made from Diecast Aluminum Alloy (alloy type 380). Silicone Gasket Loctite #5950	
PART NUMBERS	
1590K Enclosure	
Unfinished	1590K
Grey Textured Polyester Powder Paint - RAL 7038	1590KGY
Black Textured Polyester Powder Paint - RAL 9011	1590KBK
1590K Liquid Resistant Enclosure (Silicon Factory Installed Gasket)	
Unfinished	1590WK
Black Textured Powder Paint	1590WKBK
ACCESSORIES	
Recommended Torque: 75 ozf.in / 55 cN.m	
Black Textured Cover Screws (Pkg 50) [6-32 x 1/2" SS Type 304]	1590WMS100BK
Unfinished Cover Screws (Pkg 100) [6-32 x 1/2" Nickel Plated Screws]	1590WMS100
Standard Cover Screws	
Unfinished Cover Screws (Pkg 100) [6-32 x 1/2" Nickel Plated Screws]	1590MS100
Black Textured Cover Screws (Pkg 50) [6-32 x 1/2" SS Type 304]	1590MS100BK

**HAMMOND  
MANUFACTURING™**

**1590K**

[www.hammondmg.com](http://www.hammondmg.com)

### Top View of Assembly

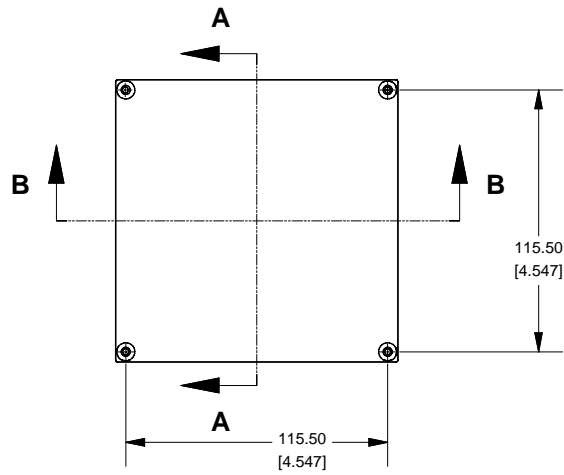

### SECTION A-A End View of Assembly

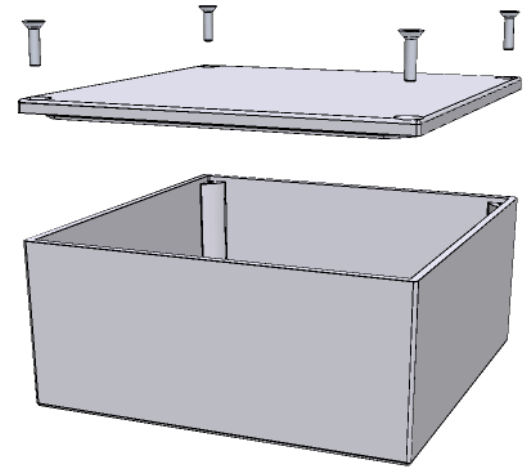
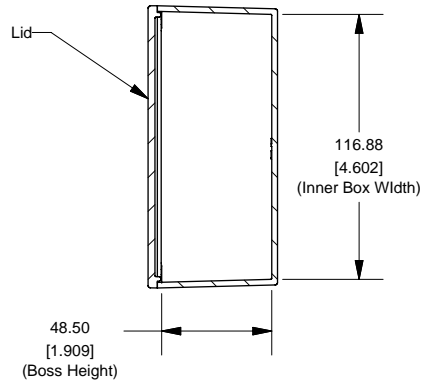

### SECTION B-B Side View of Assembly

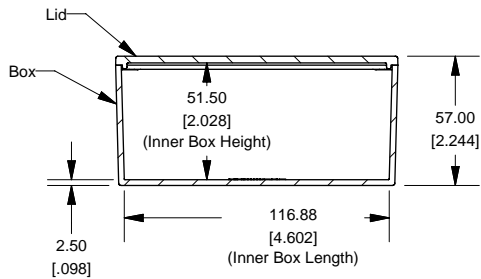

### Top View Looking Inside Box

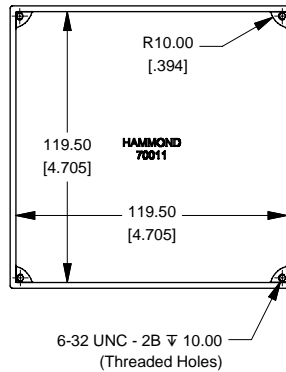

### Lid

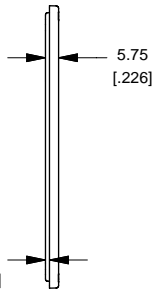
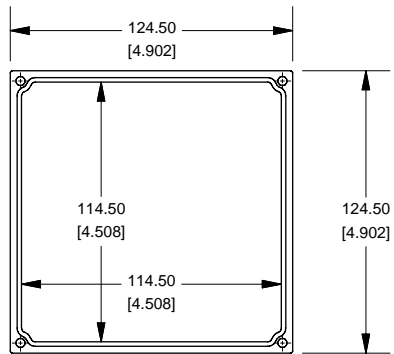

Enclosures can be Factory Modified ( Milling, Drilling, Printing etc.)  
Contact Factory [mjm@hammondmfg.com](mailto:mjm@hammondmfg.com) for quotes  
Solid models of this enclosure available in STEP or IGES.

#### NOTE

Purchased assembly includes box, lid and 4 cover screws.  
Box and lid are made from Diecast Aluminum Alloy (alloy type 380).  
Silicone Gasket Loctite #5950

#### PART NUMBERS

<b>1590KK Enclosure</b>	
Unfinished	1590KK
Grey Textured Polyester Powder Paint - RAL 7038	1590KKGY
Black Textured Polyester Powder Paint - RAL 9011	1590KKBK
<b>1590KK Liquid Resistant Enclosure (Silicon Factory Installed Gasket)</b>	
Unfinished	1590WKK
Black Textured Powder Paint	1590WKKBK
<b>ACCESSORIES</b>	
<b>Recommended Torque: 75 ozf.in / 55 cN.m</b>	
Black Textured Cover Screws (Pkg 50) [6-32 x 1/2" SS Type 304]	1590WMS100BK
Unfinished Cover Screws (Pkg 100) [6-32 x 1/2" Nickel Plated Screws]	1590WMS100
<b>Standard Cover Screws</b>	
Unfinished Cover Screws (Pkg 100) [6-32 x 1/2" Nickel Plated Screws]	1590MS100
Black Textured Cover Screws (Pkg 50) [6-32 x 1/2" SS Type 304]	1590MS100BK

**HAMMOND MANUFACTURING™**  
1590KK  
[www.hammondmfg.com](http://www.hammondmfg.com)

### Top View of Assembly

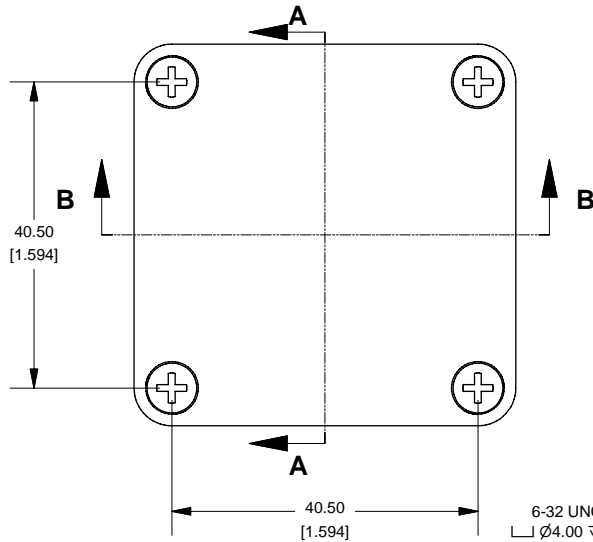

### SECTION A-A End View of Assembly

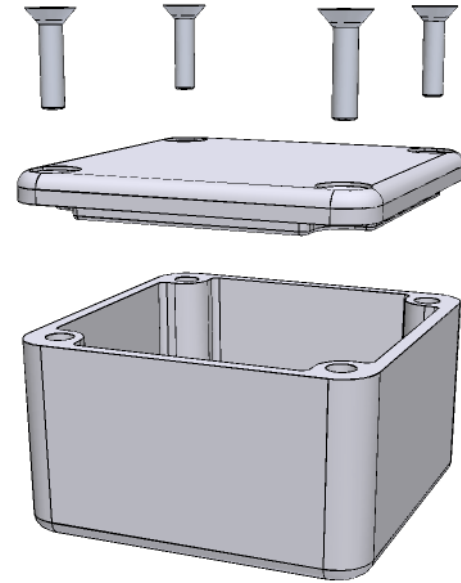
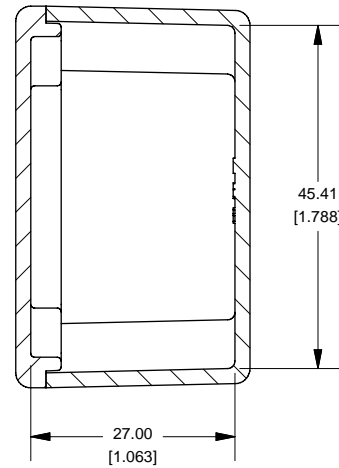

### SECTION B-B Side View of Assembly

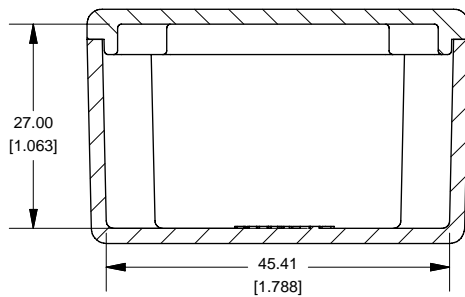

### Top View Looking Inside Box

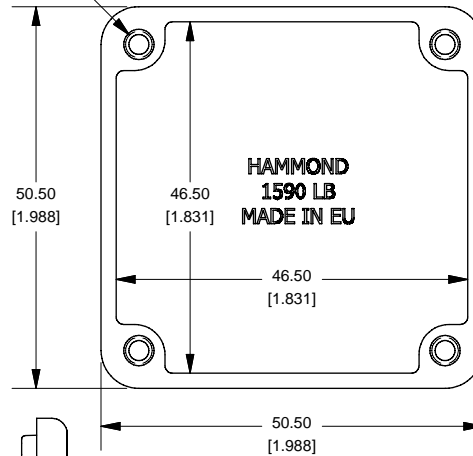

### Lid

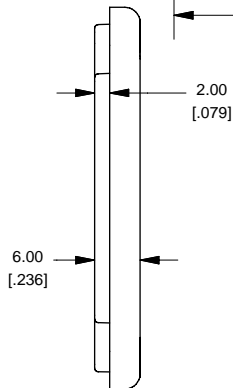
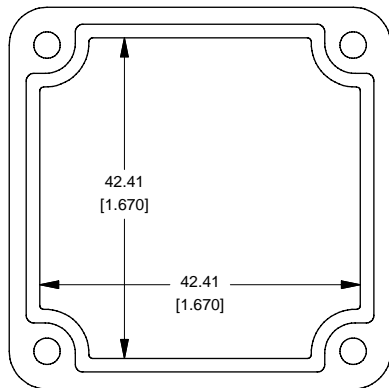

Enclosures can be Factory Modified ( Milling, Drilling, Printing etc.)  
 Contact Factory [mjm@hammondmfg.com](mailto:mjm@hammondmfg.com) for quotes  
 Solid models of this enclosure available in STEP or IGES.

#### NOTE

Purchased assembly includes box, lid and 4 cover screws.  
 Box and lid are made from Diecast Aluminum Alloy (alloy type 380).  
 Silicone Gasket Loctite #5950

#### PART NUMBERS

1590LB Enclosure	
Unfinished	1590LB
Grey Textured Polyester Powder Paint - RAL 7038	1590LBGY
Black Textured Polyester Powder Paint - RAL 9011	1590LBBK
1590LB Liquid Resistant Enclosure (Silicon Factory Installed Gasket)	
Unfinished	1590WLB
Black Textured Powder Paint	1590WLBK
ACCESSORIES	
Recommended Torque: 75 ozf.in / 55 cN.m	
Black Textured Cover Screws (Pkg 50) [6-32 x 1/2" SS Type 304]	1590WMS100BK
Unfinished Cover Screws (Pkg 100) [6-32 x 1/2" Nickel Plated Screws]	1590WMS100
Standard Cover Screws	
Unfinished Cover Screws (Pkg 100) [6-32 x 1/2" Nickel Plated Screws]	1590MS100
Black Textured Cover Screws (Pkg 50) [6-32 x 1/2" SS Type 304]	1590MS100BK



**HAMMOND  
MANUFACTURING™**

**1590LB**

[www.hammondmfg.com](http://www.hammondmfg.com)

### Top View of Assembly

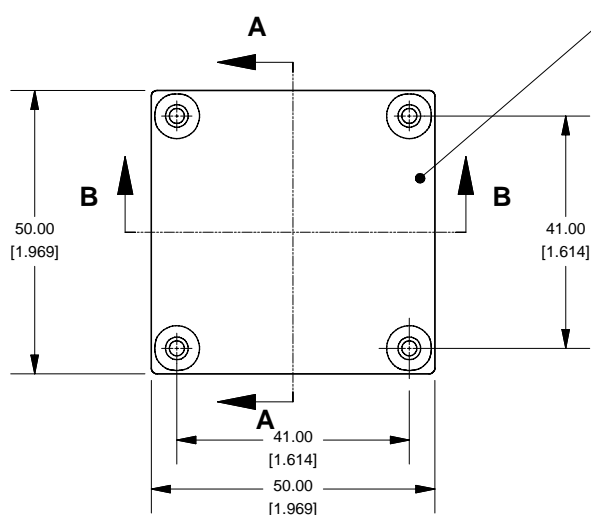

### SECTION A-A End View of Assembly

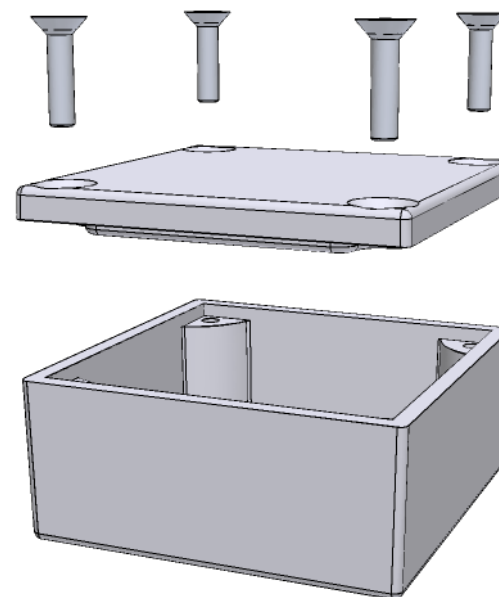
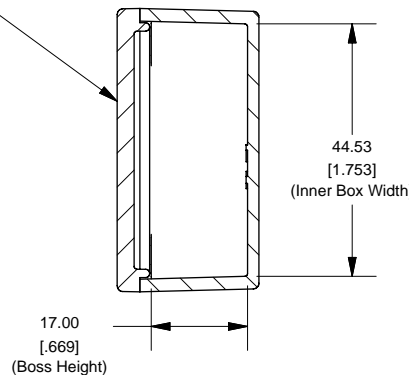

### SECTION B-B Side View of Assembly

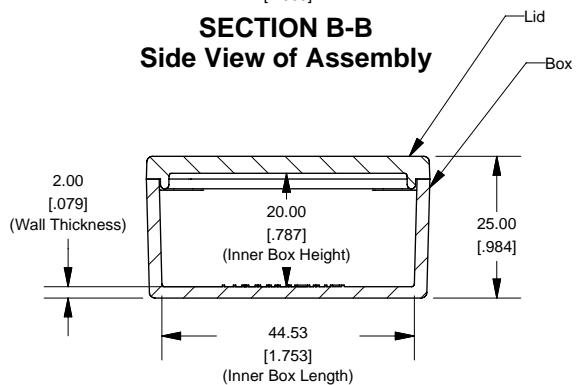

### Top View Looking Inside Box

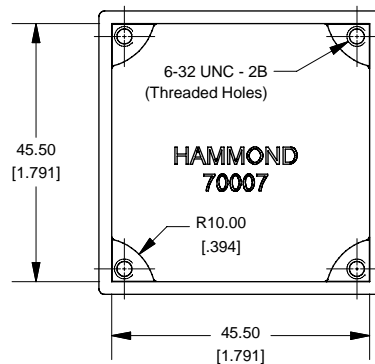

### Lid

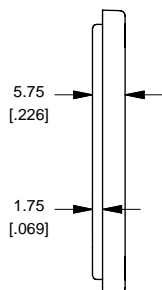
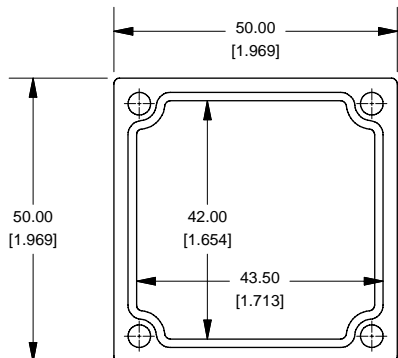

Enclosures can be Factory Modified ( Milling, Drilling, Printing etc.)  
 Contact Factory [mjm@hammondmfg.com](mailto:mjm@hammondmfg.com) for quotes  
 Solid models of this enclosure available in STEP or IGES.

NOTE	
Purchased assembly includes box, lid and 4 cover screws. Box and lid are made from Diecast Aluminum Alloy (alloy type 380). Silicone Gasket Loctite #5950	
PART NUMBERS	
1590LLB Enclosure	
Unfinished	1590LLB
Grey Textured Polyester Powder Paint - RAL 7038	1590LLBGY
Black Textured Polyester Powder Paint - RAL 9011	1590LLBKB
1590LLB Liquid Resistant Enclosure (Silicon Factory Installed Gasket)	
Unfinished	1590WLLB
Black Textured Powder Paint	1590WLLBKB
ACCESSORIES	
Recommended Torque: 75 ozf.in / 55 cN.m	
Black Textured Cover Screws (Pkg 50) [6-32 x 1/2" SS Type 304]	1590WMS100BK
Unfinished Cover Screws (Pkg 100) [6-32 x 1/2" Nickel Plated Screws]	1590WMS100
Standard Cover Screws	
Unfinished Cover Screws (Pkg 100) [6-32 x 1/2" Nickel Plated Screws]	1590MS100
Black Textured Cover Screws (Pkg 50) [6-32 x 1/2" SS Type 304]	1590MS100BK

**HAMMOND  
MANUFACTURING™**

**1590LLB**

[www.hammondmfg.com](http://www.hammondmfg.com)

**Top View of Assembly**

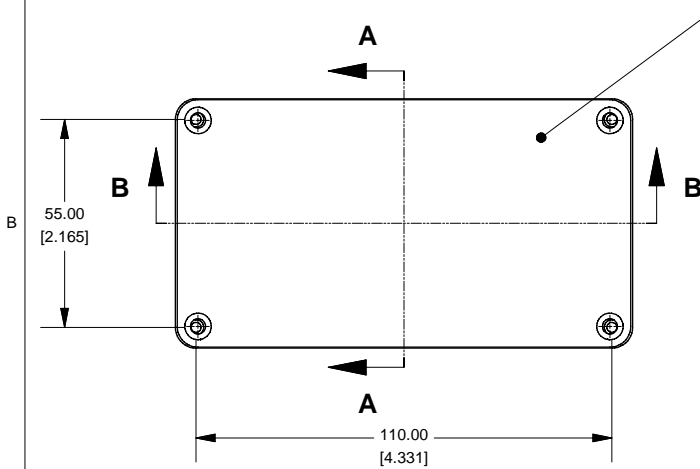

**SECTION A-A  
End View of Assembly**

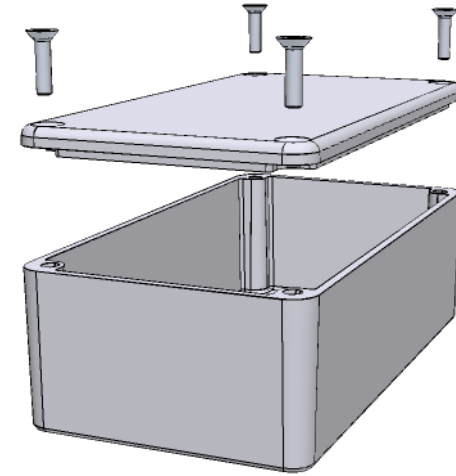
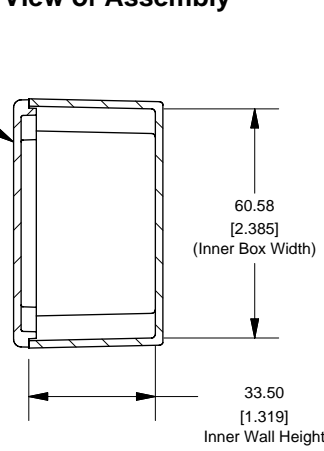

**SECTION B-B  
Side View of Assembly**

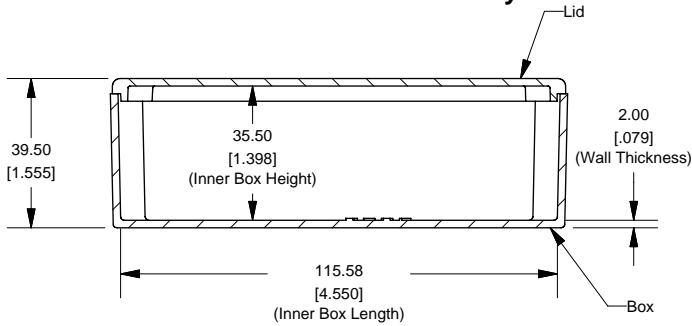

**Top View Looking Inside Box**

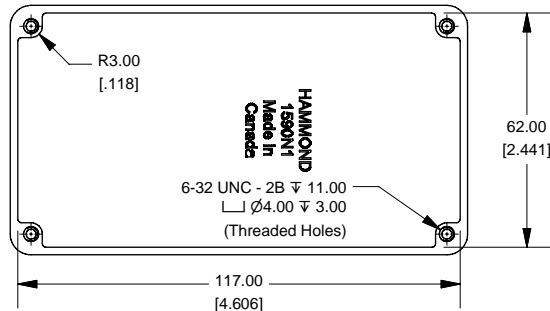

Enclosures can be Factory Modified ( Milling, Drilling, Printing etc.)  
Contact Factory [mjm@hammondmfg.com](mailto:mjm@hammondmfg.com) for quotes  
Solid models of this enclosure available in STEP or IGES.

**Lid**

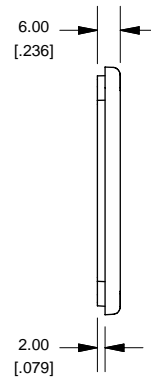
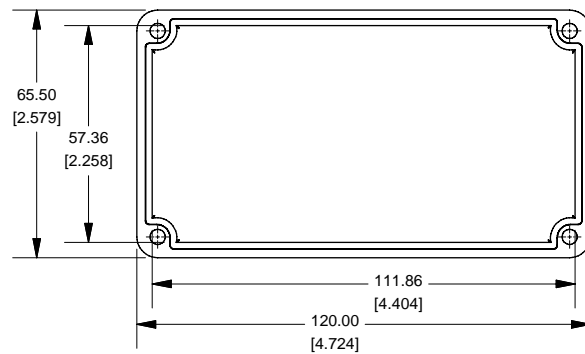

NOTE	
Purchased assembly includes box, lid and 4 cover screws. Box and lid are made from Diecast Aluminum Alloy (alloy type 380). Silicone Gasket Loctite #5950	
PART NUMBERS	
1590N1 Enclosure	
Unfinished	1590N1
Grey Textured Polyester Powder Paint - RAL 7038	1590N1GY
Black Textured Polyester Powder Paint - RAL 9011	1590N1BK
1590N1 Liquid Resistant Enclosure (Silicon Factory Installed Gasket)	
Unfinished	1590WN1
Black Textured Powder Paint	1590WNBK
ACCESSORIES	
Recommended Torque: 75 ozf.in / 55 cN.m	
Black Textured Cover Screws (Pkg 50) [6-32 x 1/2" SS Type 304]	1590WMS100BK
Unfinished Cover Screws (Pkg 100) [6-32 x 1/2" Nickel Plated Screws]	1590WMS100
Standard Cover Screws	
Unfinished Cover Screws (Pkg 100) [6-32 x 1/2" Nickel Plated Screws]	1590MS100
Black Textured Cover Screws (Pkg 50) [6-32 x 1/2" SS Type 304]	1590MS100BK





### Top View of Assembly

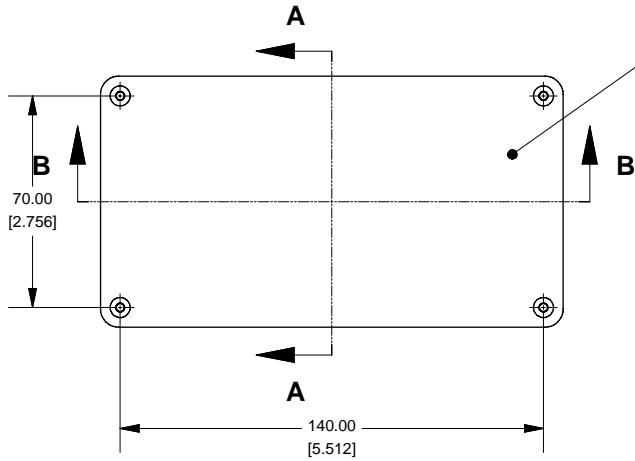

### SECTION A-A End View of Assembly

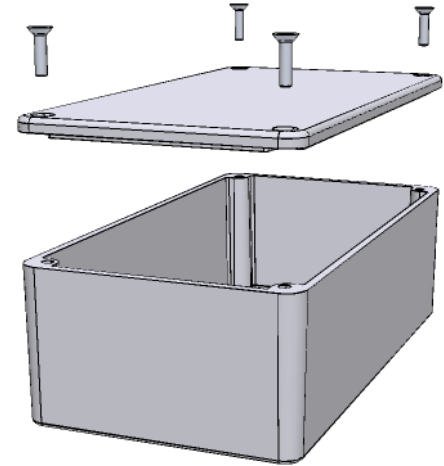
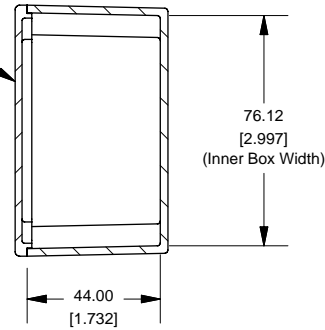

### SECTION B-B Side View of Assembly

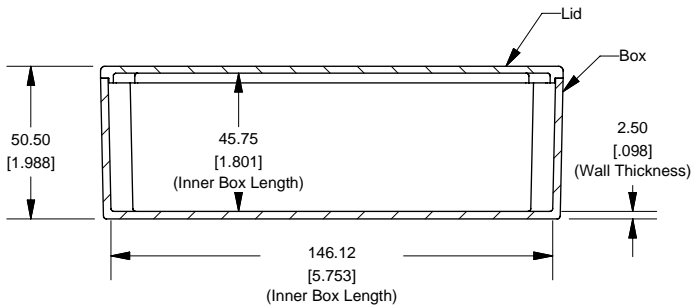

### Top View Looking Inside Box

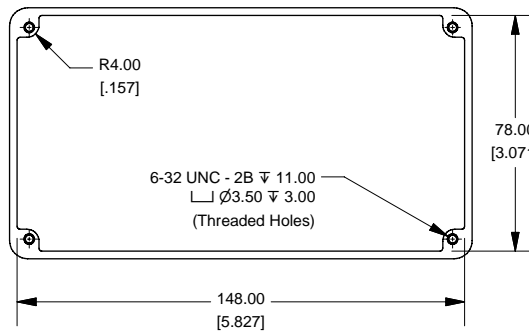

Enclosures can be Factory Modified ( Milling, Drilling, Printing etc.)  
Contact Factory [mjm@hammondmfg.com](mailto:mjm@hammondmfg.com) for quotes  
Solid models of this enclosure available in STEP or IGES.

NOTE	
Purchased assembly includes box, lid and 4 cover screws.	
Box and lid are made from Diecast Aluminum Alloy (alloy type 380).	
Silicone Gasket Loctite #5950	
PART NUMBERS	
1590P1 Enclosure	
Unfinished	1590P1
Grey Textured Polyester Powder Paint - RAL 7038	1590P1GY
Black Textured Polyester Powder Paint - RAL 9011	1590P1BK
1590P1 Liquid Resistant Enclosure (Silicon Factory Installed Gasket)	
Unfinished	1590WP1
Black Textured Powder Paint	1590WP1BK
ACCESSORIES	
Recommended Torque: 75 ozf.in / 55 cN.m	
Black Textured Cover Screws (Pkg 50) [6-32 x 1/2" SS Type 304]	1590WMS100BK
Unfinished Cover Screws (Pkg 100) [6-32 x 1/2" Nickel Plated Screws]	1590WMS100
Standard Cover Screws	
Unfinished Cover Screws (Pkg 100) [6-32 x 1/2" Nickel Plated Screws]	1590MS100
Black Textured Cover Screws (Pkg 50) [6-32 x 1/2" SS Type 304]	1590MS100BK

### Lid

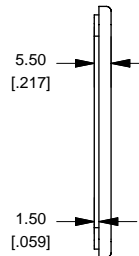
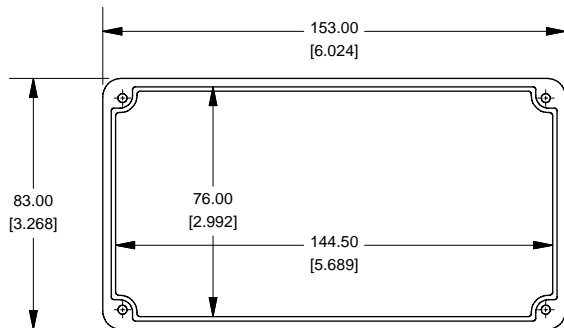

**HAMMOND  
MANUFACTURING™**  
1590P1  
[www.hammondmfg.com](http://www.hammondmfg.com)

### Top View of Assembly

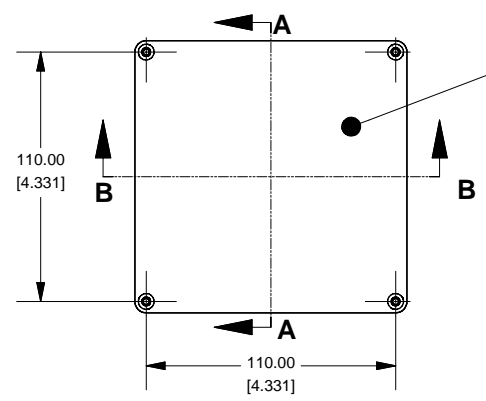

### SECTION A-A Side View of Assembly

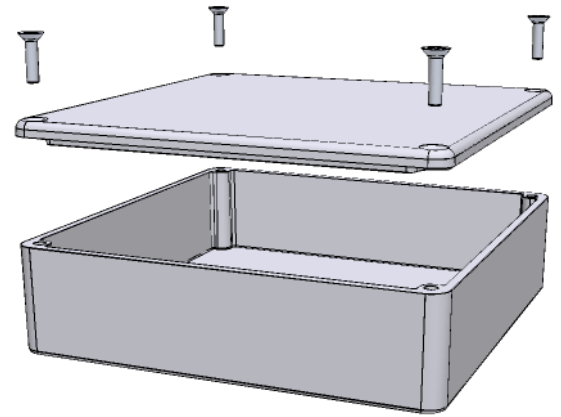
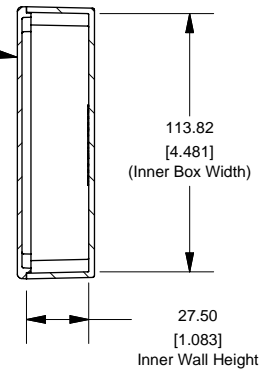

### Top View Looking Inside Box

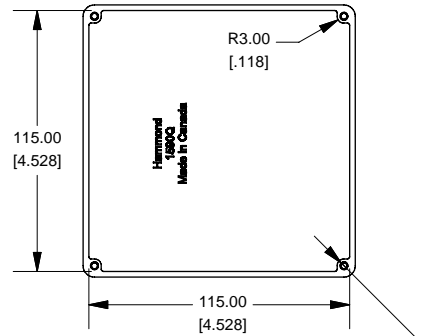

### SECTION B-B End View of Assembly

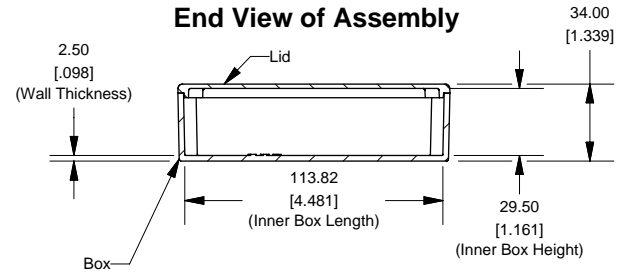

### Lid

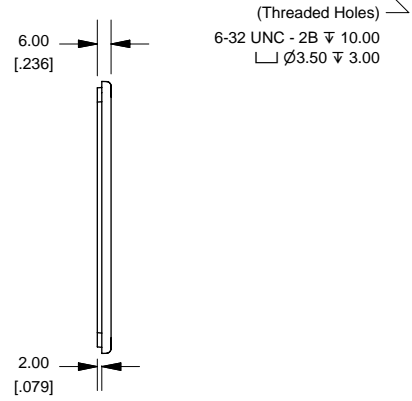
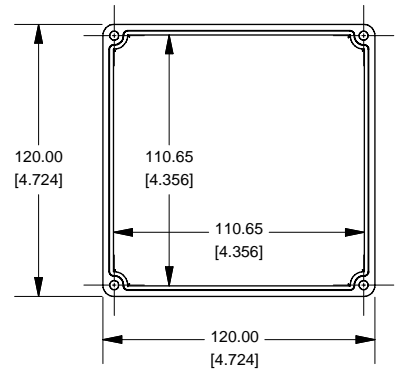

Enclosures can be Factory Modified ( Milling, Drilling, Printing etc.)  
Contact Factory [mjm@hammondmfg.com](mailto:mjm@hammondmfg.com) for quotes  
Solid models of this enclosure available in STEP or IGES.

NOTE	
Purchased assembly includes box, lid and 4 cover screws. Box and lid are made from Diecast Aluminum Alloy (alloy type 380). Silicone Gasket Loctite #5950	
PART NUMBERS	
1590Q Enclosure	
Unfinished	1590Q
Grey Textured Polyester Powder Paint - RAL 7038	1590QQY
Black Textured Polyester Powder Paint - RAL 9011	1590QBK
1590Q Liquid Resistant Enclosure (Silicon Factory Installed Gasket)	
Unfinished	1590WQ
Black Textured Powder Paint	1590WQBK
ACCESSORIES	
Recommended Torque: 75 ozf.in / 55 cN.m	
Black Textured Cover Screws (Pkg 50) [6-32 x 1/2" SS Type 304]	1590WMS100BK
Unfinished Cover Screws (Pkg 100) [6-32 x 1/2" Nickel Plated Screws]	1590WMS100
Standard Cover Screws	
Unfinished Cover Screws (Pkg 100) [6-32 x 1/2" Nickel Plated Screws]	1590MS100
Black Textured Cover Screws (Pkg 50) [6-32 x 1/2" SS Type 304]	1590MS100BK

**HAMMOND MANUFACTURING™**  
1590Q  
[www.hammondmfg.com](http://www.hammondmfg.com)

### Top View of Assembly

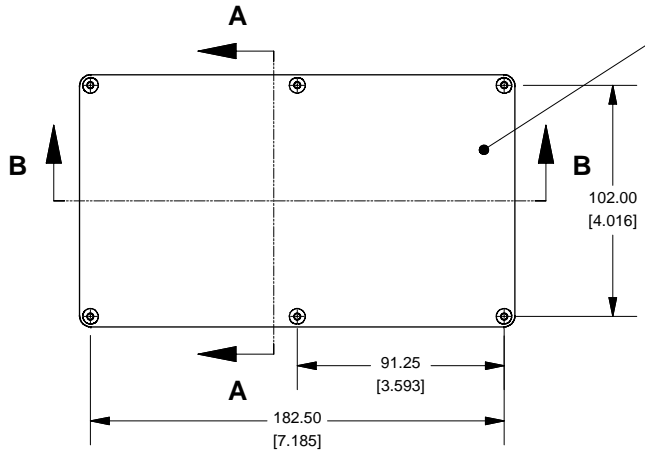

### SECTION A-A End View of Assembly

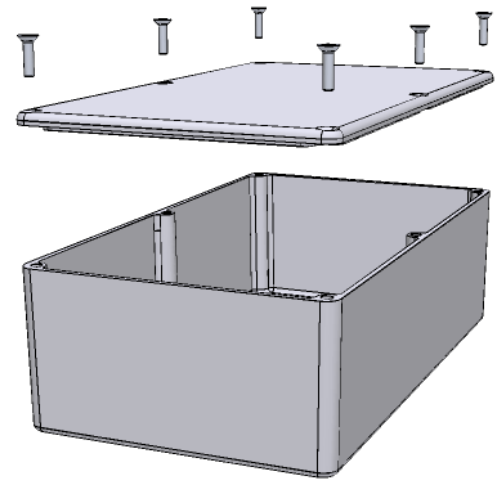
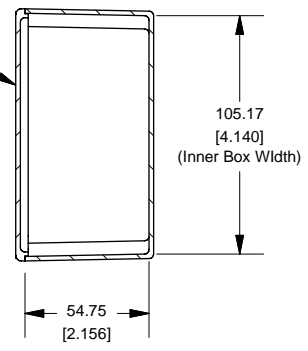

### SECTION B-B Side View of Assembly

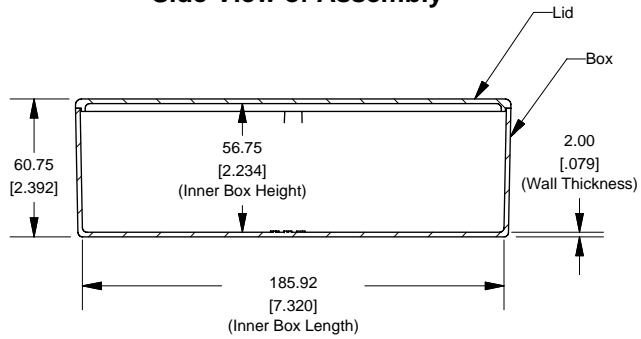

### Top View Looking Inside Box

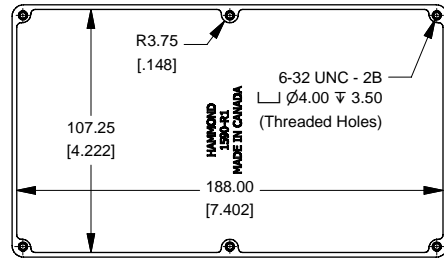

Enclosures can be Factory Modified ( Milling, Drilling, Printing etc.)  
 Contact Factory [mjm@hammondmfg.com](mailto:mjm@hammondmfg.com) for quotes  
 Solid models of this enclosure available in STEP or IGES.

#### NOTE

Purchased assembly includes box, lid and 6 cover screws.  
 Box and lid are made from Diecast Aluminum Alloy (alloy type 380).  
 Silicone Gasket Loctite #5950

#### PART NUMBERS

1590R1 Enclosure	
Unfinished	1590R1
Grey Textured Polyester Powder Paint - RAL 7038	1590R1GY
Black Textured Polyester Powder Paint - RAL 9011	1590R1BK
1590R1 Liquid Resistant Enclosure (Silicon Factory Installed Gasket)	
Unfinished	1590WR1
Black Textured Powder Paint	1590WR1BK
ACCESSORIES	
Recommended Torque: 75 ozf.in / 55 cN.m	
Black Textured Cover Screws (Pkg 50) [6-32 x 1/2" SS Type 304]	1590WMS100BK
Unfinished Cover Screws (Pkg 100) [6-32 x 1/2" Nickel Plated Screws]	1590WMS100
Standard Cover Screws	
Unfinished Cover Screws (Pkg 100) [6-32 x 1/2" Nickel Plated Screws]	1590MS100
Black Textured Cover Screws (Pkg 50) [6-32 x 1/2" SS Type 304]	1590MS100BK

### Lid

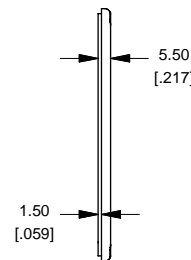
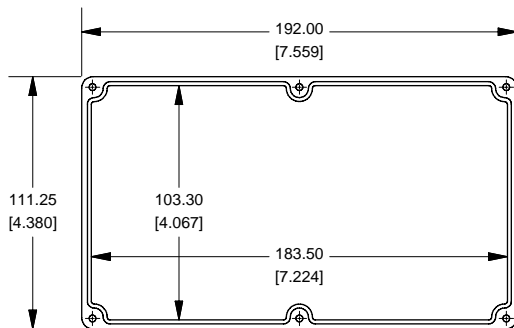

**HAMMOND MANUFACTURING™**  
 1590R1  
[www.hammondmfg.com](http://www.hammondmfg.com)

### Top View of Assembly

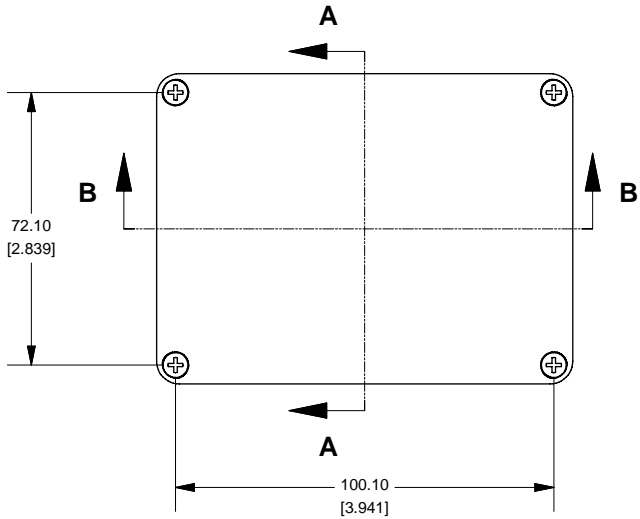

### SECTION A-A End View of Assembly

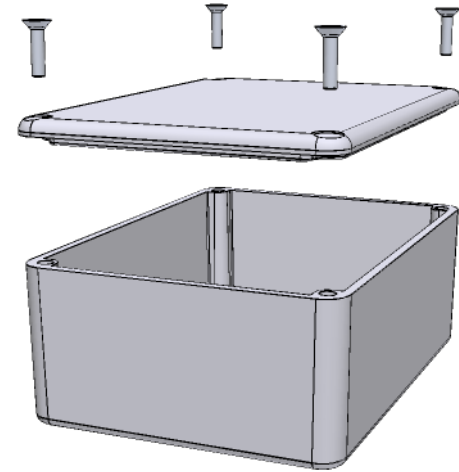
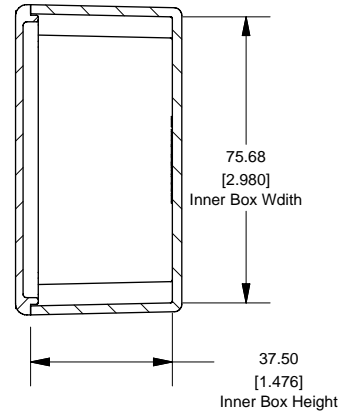

### SECTION B-B Side View of Assembly

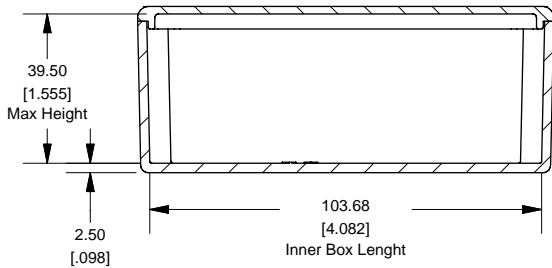

### Top View Looking Inside Box

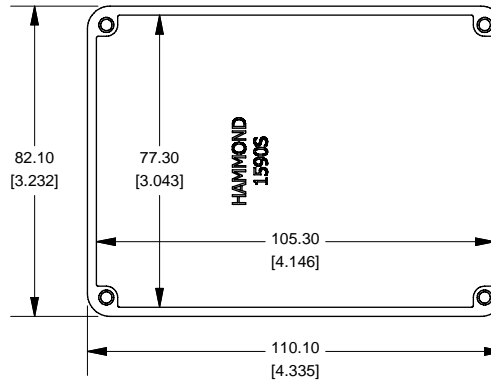

Enclosures can be Factory Modified ( Milling, Drilling, Printing etc.)  
Contact Factory [mjm@hammondmfg.com](mailto:mjm@hammondmfg.com) for quotes  
Solid models of this enclosure available in STEP or IGES.

#### NOTE

Purchased assembly includes box, lid and 4 cover screws.  
Box and lid are made from Diecast Aluminum Alloy (alloy type 380).  
Silicone Gasket Loctite #5950

#### PART NUMBERS

1590S Enclosure	
Unfinished	1590S
Grey Textured Polyester Powder Paint - RAL 7038	1590SGY
Black Textured Polyester Powder Paint - RAL 9011	1590SBK
1590S Liquid Resistant Enclosure (Silicon Factory Installed Gasket)	
Unfinished	1590WS
Black Textured Powder Paint	1590WSBK
ACCESSORIES	
Recommended Torque: 75 oz.in / 55 cN.m	
Black Textured Cover Screws (Pkg 50) [6-32 x 1/2" SS Type 304]	1590WMS100BK
Unfinished Cover Screws (Pkg 100) [6-32 x 1/2" Nickel Plated Screws]	1590WMS100
Standard Cover Screws	
Unfinished Cover Screws (Pkg 100) [6-32 x 1/2" Nickel Plated Screws]	1590MS100
Black Textured Cover Screws (Pkg 50) [6-32 x 1/2" SS Type 304]	1590MS100BK

### Lid

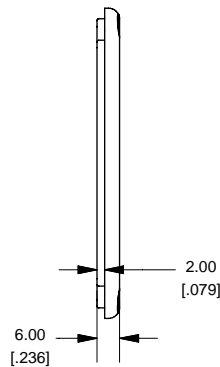
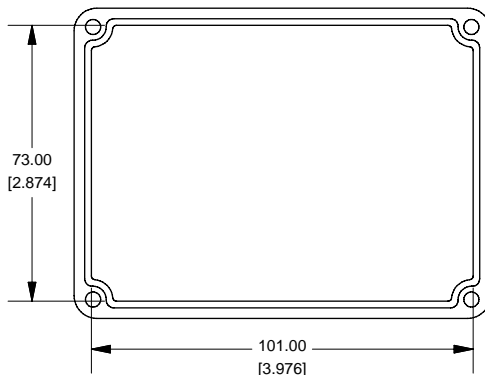

**HAMMOND MANUFACTURING™**  
1590S  
[www.hammondmfg.com](http://www.hammondmfg.com)

### Top View of Assembly

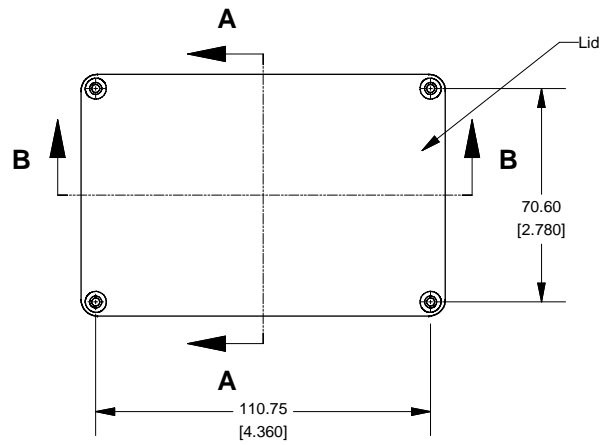

### SECTION A-A End View of Assembly

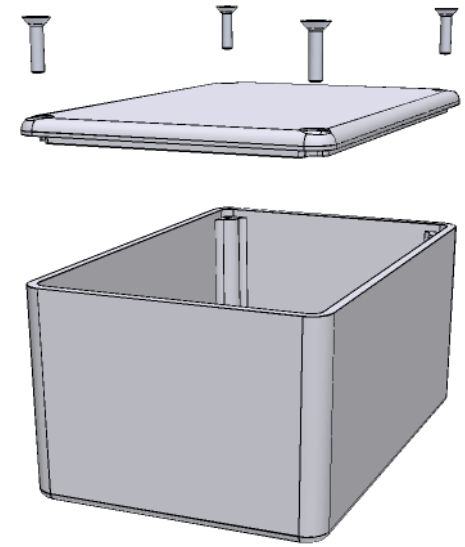
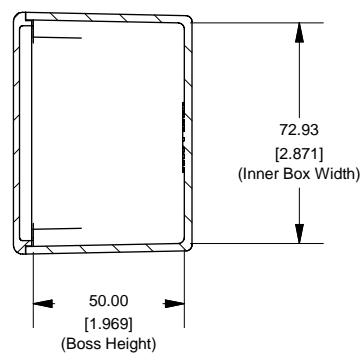

### SECTION B-B Side View of Assembly

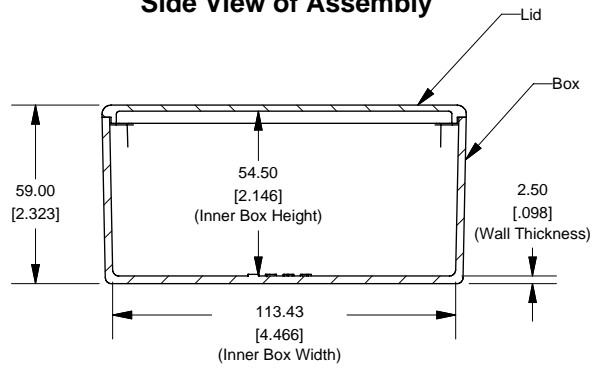

### Top View Looking Inside Box

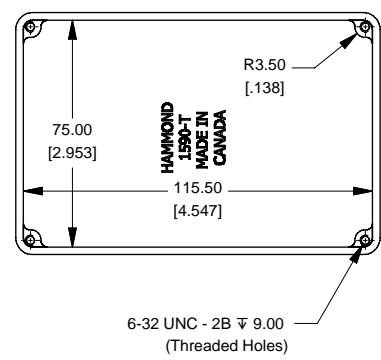

Enclosures can be Factory Modified ( Milling, Drilling, Printing etc.)  
 Contact Factory [mjm@hammondmfg.com](mailto:mjm@hammondmfg.com) for quotes  
 Solid models of this enclosure available in STEP or IGES.

#### NOTE

Purchased assembly includes box, lid and 4 cover screws.  
 Box and lid are made from Diecast Aluminum Alloy (alloy type 380).  
 Silicone Gasket Loctite #5950

#### PART NUMBERS

1590T Enclosure	
Unfinished	1590T
Grey Textured Polyester Powder Paint - RAL 7038	1590TGY
Black Textured Polyester Powder Paint - RAL 9011	1590TBK
1590T Liquid Resistant Enclosure (Silicon Factory Installed Gasket)	
Unfinished	1590WT
Black Textured Powder Paint	1590WTBK
ACCESSORIES	
Recommended Torque: 75 ozf.in / 55 cN.m	
Black Textured Cover Screws (Pkg 50) [6-32 x 1/2" SS Type 304]	1590WMS100BK
Unfinished Cover Screws (Pkg 100) [6-32 x 1/2" Nickel Plated Screws]	1590WMS100
Standard Cover Screws	
Unfinished Cover Screws (Pkg 100) [6-32 x 1/2" Nickel Plated Screws]	1590MS100
Black Textured Cover Screws (Pkg 50) [6-32 x 1/2" SS Type 304]	1590MS100BK

### Lid

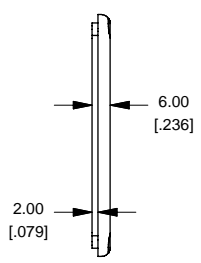
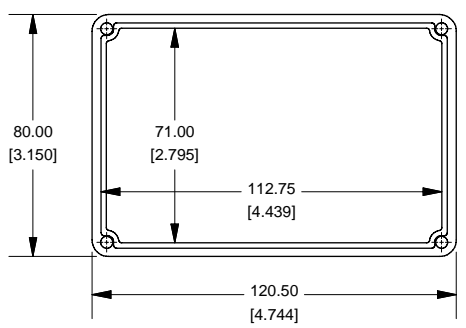

### Top View of Assembly

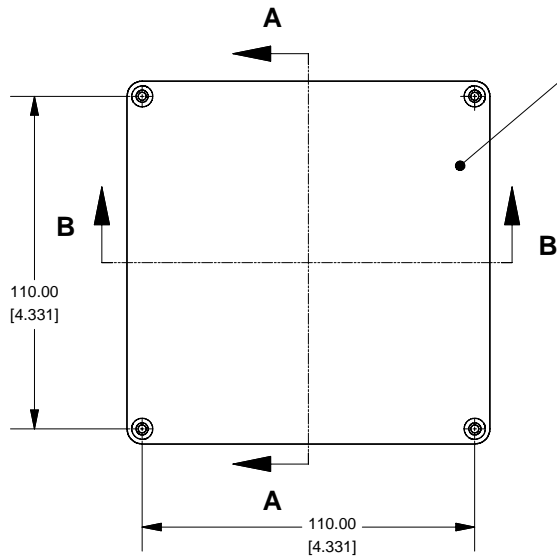

### SECTION A-A End View of Assembly

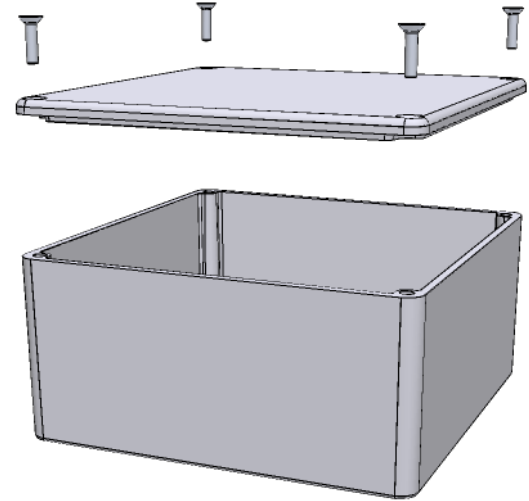
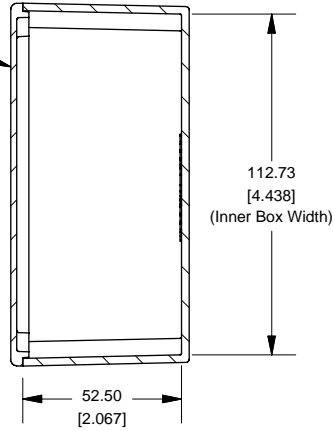

### Top View Looking Inside Box

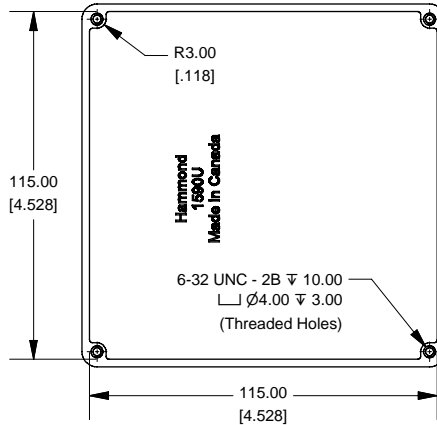

### SECTION B-B Side View of Assembly

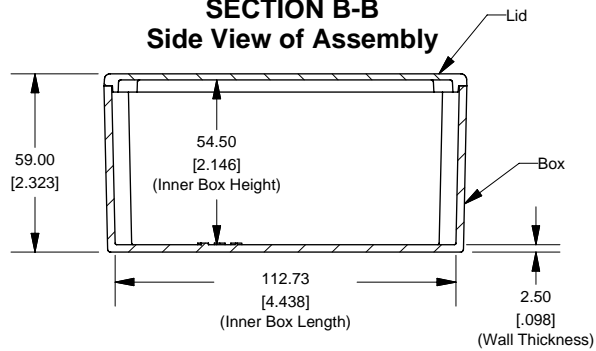

### Lid

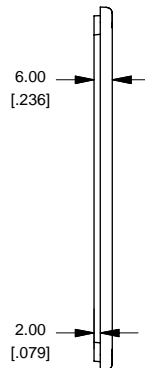
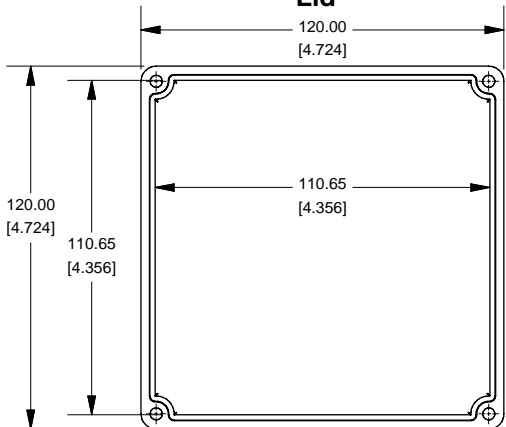

Enclosures can be Factory Modified ( Milling, Drilling, Printing etc.)  
Contact Factory [mjm@hammondmfg.com](mailto:mjm@hammondmfg.com) for quotes  
Solid models of this enclosure available in STEP or IGES.

NOTE	
Purchased assembly includes box, lid and 4 cover screws. Box and lid are made from Diecast Aluminum Alloy (alloy type 380). Silicone Gasket Loctite #5950	
PART NUMBERS	
1590U Enclosure	
Unfinished	1590U
Grey Textured Polyester Powder Paint - RAL 7038	1590UGY
Black Textured Polyester Powder Paint - RAL 9011	1590UBK
1590U Liquid Resistant Enclosure (Silicon Factory Installed Gasket)	
Unfinished	1590WU
Black Textured Powder Paint	1590WUBK
ACCESSORIES	
Recommended Torque: 75 ozf.in / 55 cN.m	
Black Textured Cover Screws (Pkg 50) [6-32 x 1/2" SS Type 304]	1590WMS100BK
Unfinished Cover Screws (Pkg 100) [6-32 x 1/2" Nickel Plated Screws]	1590WMS100
Standard Cover Screws	
Unfinished Cover Screws (Pkg 100) [6-32 x 1/2" Nickel Plated Screws]	1590MS100
Black Textured Cover Screws (Pkg 50) [6-32 x 1/2" SS Type 304]	1590MS100BK

**HAMMOND MANUFACTURING™**  
1590U  
[www.hammondmfg.com](http://www.hammondmfg.com)

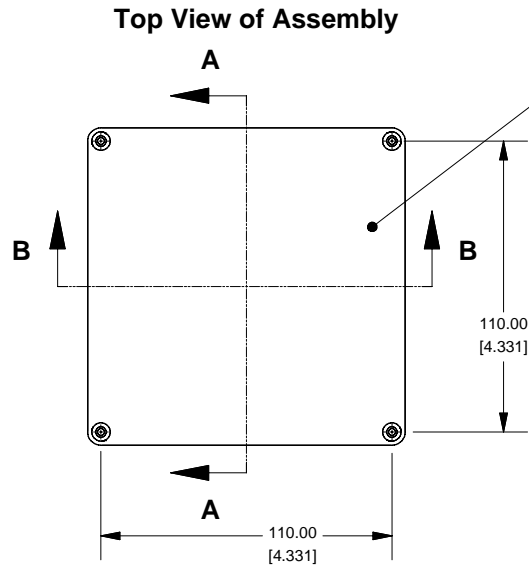

**SECTION A-A  
End View of Assembly**

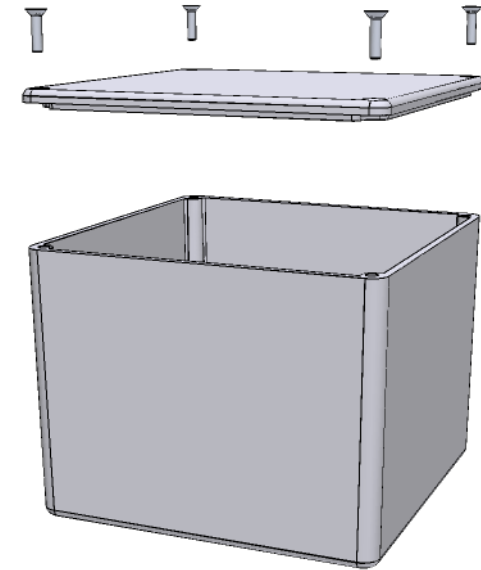
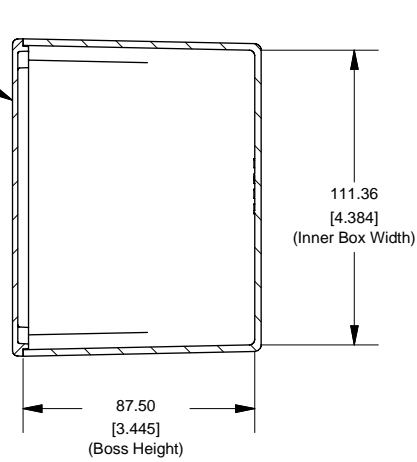

**SECTION B-B  
Side View of Assembly**

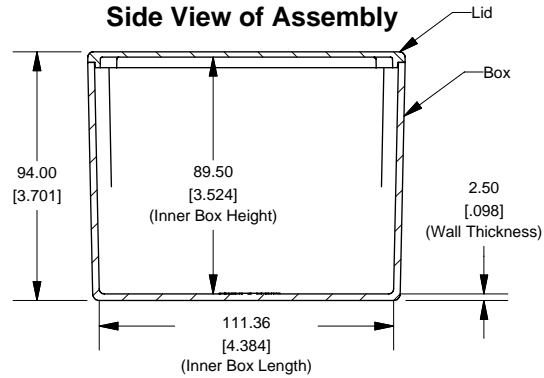

**Top View Looking Inside Box**

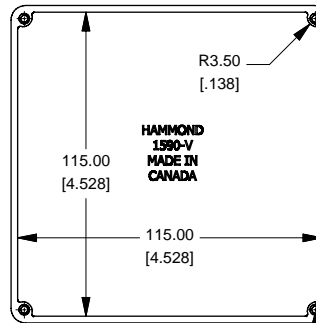

Enclosures can be Factory Modified ( Milling, Drilling, Printing etc.)  
Contact Factory [mjm@hammondmfg.com](mailto:mjm@hammondmfg.com) for quotes  
Solid models of this enclosure available in STEP or IGES.

**NOTE**

Purchased assembly includes box, lid and 4 cover screws.  
Box and lid are made from Diecast Aluminum Alloy (alloy type 380).  
Silicone Gasket Loctite #5950

**PART NUMBERS**

1590V Enclosure	
Unfinished	1590V
Grey Textured Polyester Powder Paint - RAL 7038	1590VGY
Black Textured Polyester Powder Paint - RAL 9011	1590VBK
1590V Liquid Resistant Enclosure (Silicon Factory Installed Gasket)	
Unfinished	1590VV
Black Textured Powder Paint	1590WVBK
ACCESSORIES	
Recommended Torque: 75 ozf.in / 55 cN.m	
Black Textured Cover Screws (Pkg 50) [6-32 x 1/2" SS Type 304]	1590WMS100BK
Unfinished Cover Screws (Pkg 100) [6-32 x 1/2" Nickel Plated Screws]	1590WMS100
Standard Cover Screws	
Unfinished Cover Screws (Pkg 100) [6-32 x 1/2" Nickel Plated Screws]	1590MS100
Black Textured Cover Screws (Pkg 50) [6-32 x 1/2" SS Type 304]	1590MS100BK

**Lid**

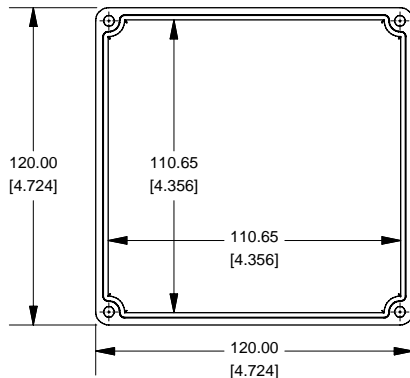

6-32 UNC - 2B  
□  $\varnothing 4.00 \nabla 3.00$   
(Threaded Holes)

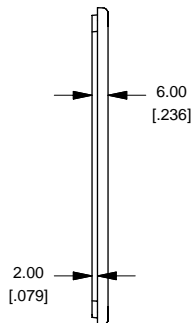

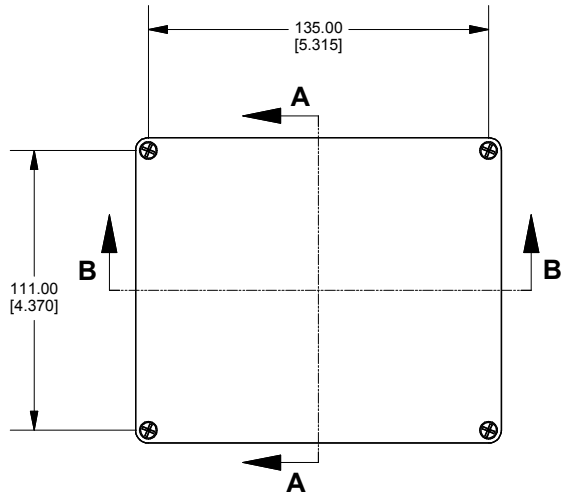

ASSEMBLY

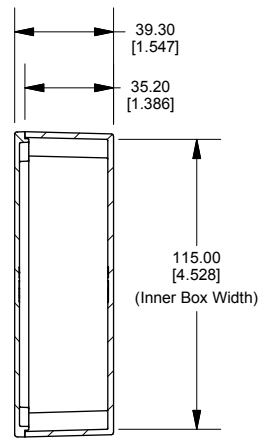

SECTION A-A

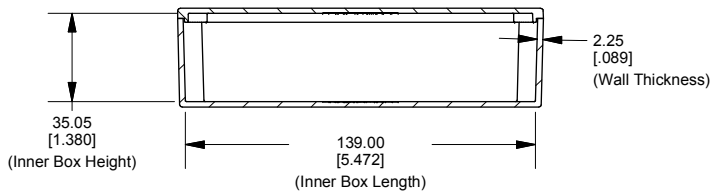
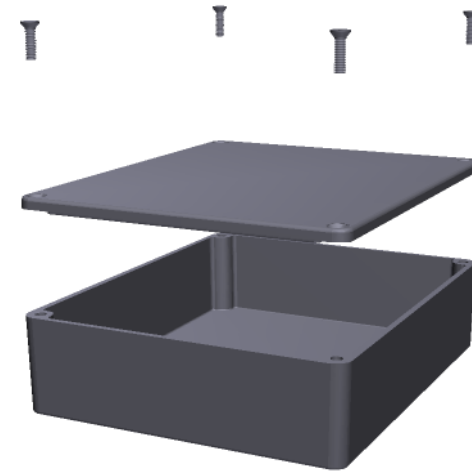

SECTION B-B

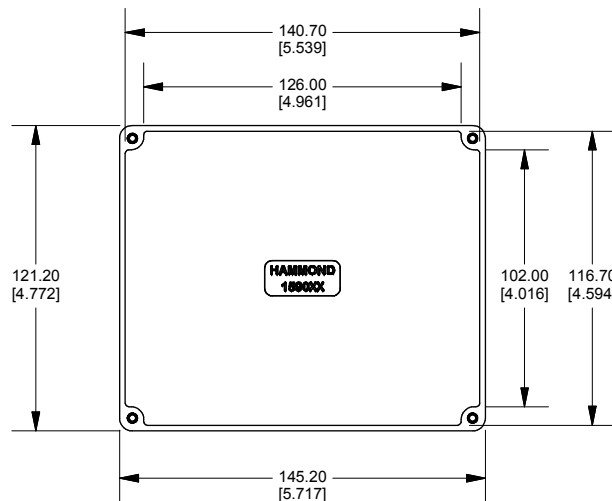

BOX - INSIDE

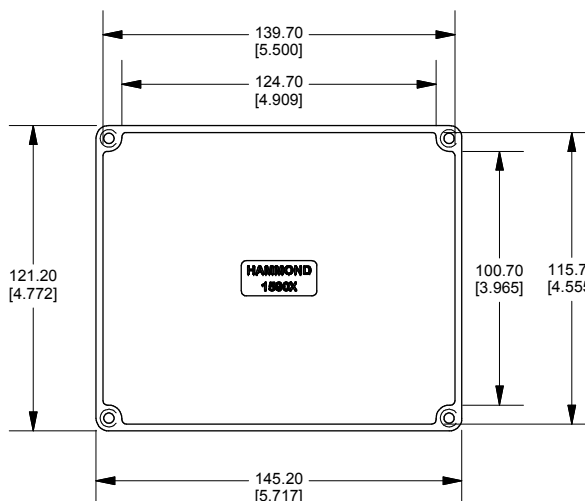

LID - INSIDE

Enclosures can be Factory Modified ( Milling, Drilling, Printing etc.)  
 Contact Factory [mjm@hammondmfg.com](mailto:mjm@hammondmfg.com) for quotes  
 Solid models of this enclosure available in STEP or IGES.

NOTE	
Purchased assembly includes box, lid and 4 cover screws. Box and lid are made from Diecast Aluminum Alloy. Silicone Gasket Loctite #5950	
PART NUMBERS	
1590XX Enclosure	
Unfinished	1590XX
Grey Textured Polyester Powder Paint - RAL 7038	1590XXGY
Black Textured Polyester Powder Paint - RAL 9011	1590XXBK
1590XX Liquid Resistant Enclosure (Silicon Factory Installed Gasket)	
Unfinished	1590WXX
Black Textured Powder Paint	1590WXXBK
ACCESSORIES	
Recommended Torque: 75 ozf.in / 55 cN.m	
Black Textured Cover Screws (Pkg 100) [6-32 x 1/2" SS Type 304]	1590WMS100BK
Unfinished Cover Screws (Pkg 100) [6-32 x 1/2" SS Type 304]	1590WMS100
Standard Cover Screws	
Unfinished Cover Screws (Pkg 100) [6-32 x 1/2" Nickel Plated Screws]	1590MS100
Black Textured Cover Screws (Pkg 50) [6-32 x 1/2" Nickel Plated Screws]	1590MS50BK





### Top View of Assembly

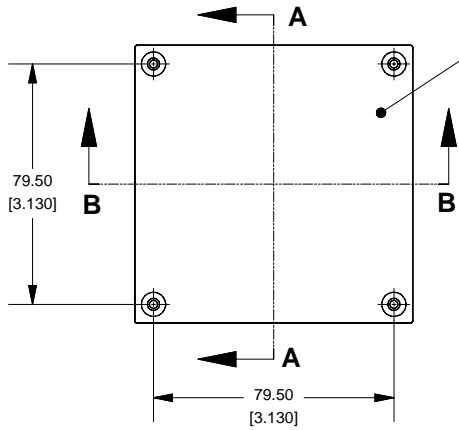

### SECTION A-A End View of Assembly

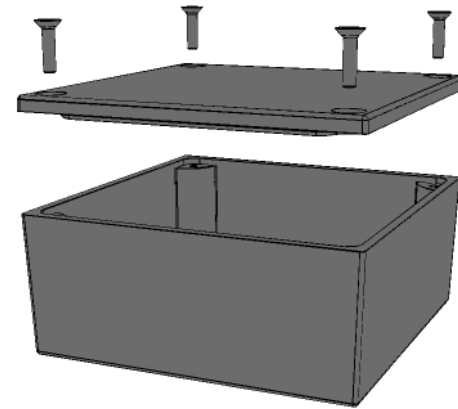
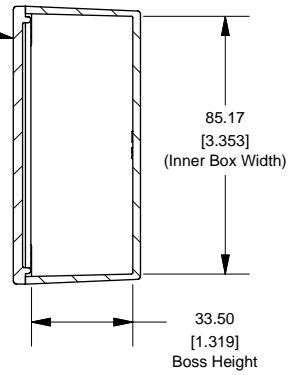

### SECTION B-B Side View of Assembly

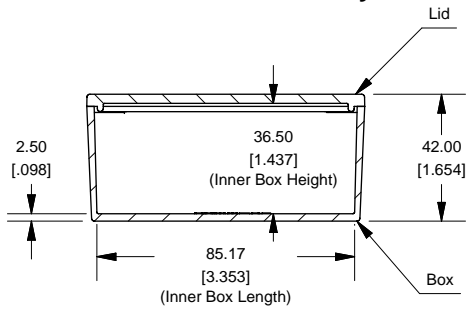

### Top View Looking Inside Box

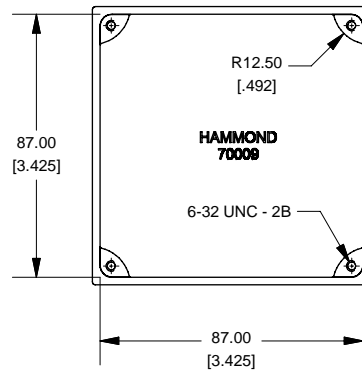

Enclosures can be Factory Modified ( Milling, Drilling, Printing etc.)  
 Contact Factory [mjm@hammondmfg.com](mailto:mjm@hammondmfg.com) for quotes  
 Solid models of this enclosure available in STEP or IGES.

#### NOTE

Purchased assembly includes box, lid and 4 cover screws.  
 Box and lid are made from Diecast Aluminum Alloy (alloy type 380).  
 Silicone Gasket Loctite #5950

#### PART NUMBERS

##### 1590Y Enclosure

Unfinished	1590Y
Grey Textured Polyester Powder Paint - RAL 7038	1590YGY
Black Textured Polyester Powder Paint - RAL 9011	1590YBK

##### 1590Y Liquid Resistant Enclosure (Silicon Factory Installed Gasket)

Unfinished	1590WY
Black Textured Powder Paint	1590WYBK

#### ACCESSORIES

Recommended Torque: 75 ozf.in / 55 cN.m

Black Textured Cover Screws (Pkg 50) [6-32 x 1/2" SS Type 304]	1590WMS100BK
Unfinished Cover Screws (Pkg 100) [6-32 x 1/2" Nickel Plated Screws]	1590WMS100

#### Standard Cover Screws

Unfinished Cover Screws (Pkg 100) [6-32 x 1/2" Nickel Plated Screws]	1590MS100
Black Textured Cover Screws (Pkg 50) [6-32 x 1/2" SS Type 304]	1590MS100BK

### Lid

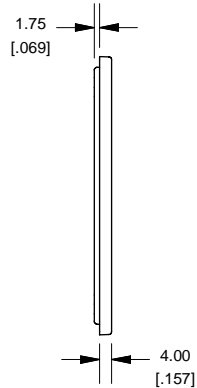
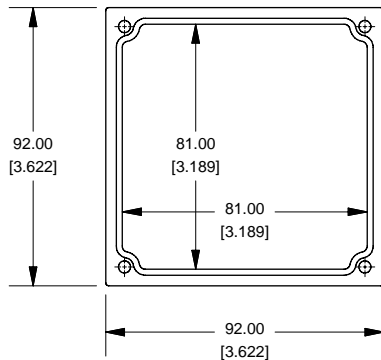

**HAMMOND  
MANUFACTURING™**

1590Y

[www.hammondmfg.com](http://www.hammondmfg.com)