

MATERIALS:

PLASTIC HOUSING: ENGINEERING THERMOPLASTIC
 FLAMMABILITY RATING UL 94V-0.

CONTACTS: PHOSPHOR BRONZE

PLATING: GOLD PLATING OVER NICKEL IN CONTACT.
 TIN PLATING OVER NICKEL IN SOLDER AREA.

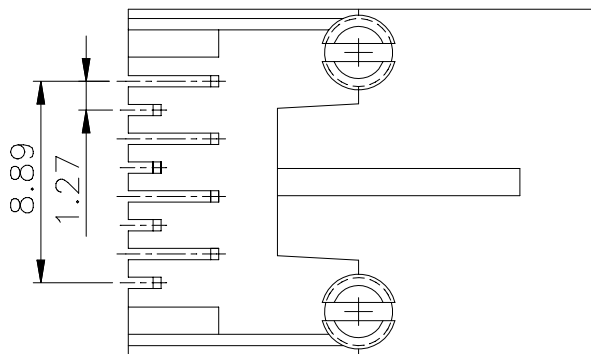
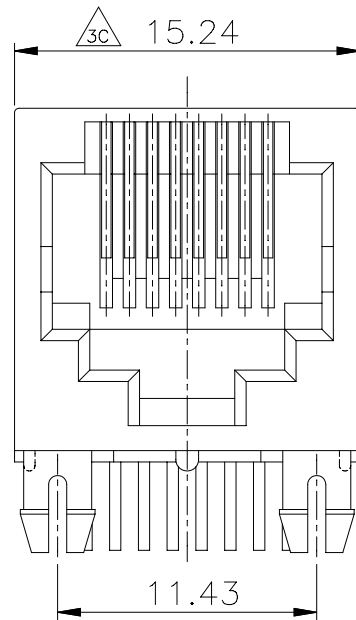
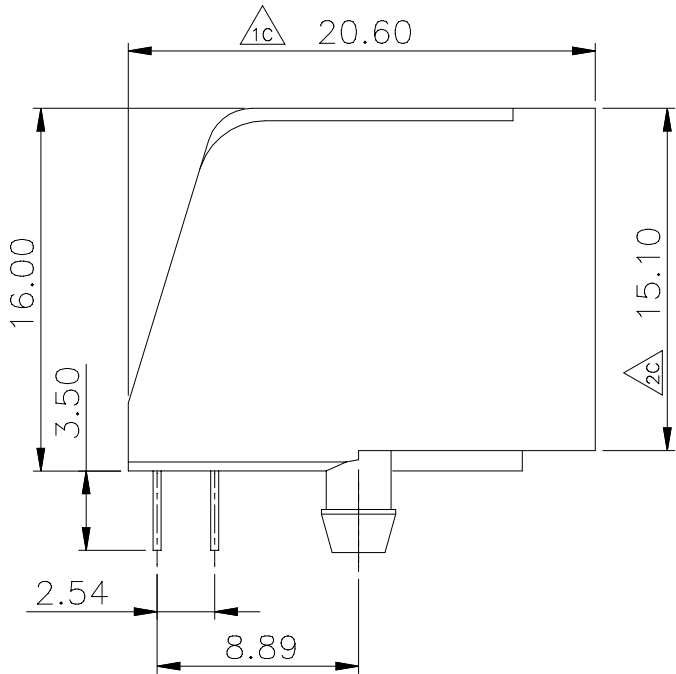

PCB LAYOUT/TOP VIEW

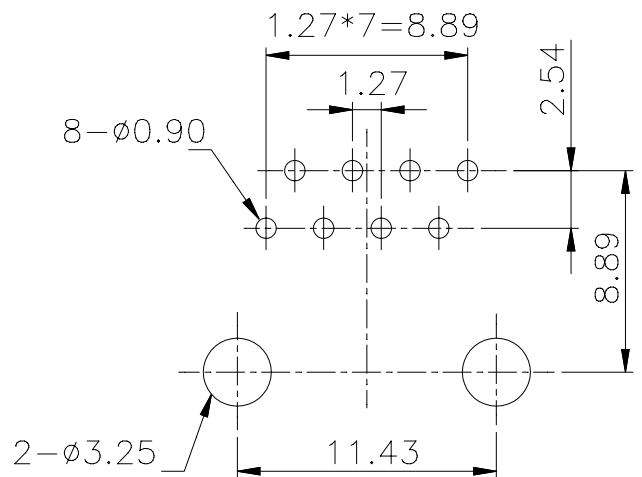

※凡標註 △記號者, 為品管檢驗之尺寸

- 6u" P/N 3001685800
- 15u" P/N 3001686400
- 30u" P/N 3001687000
- 50u" P/N 3001687600

Maritex

設計 DR. LILY 87-08-28	核准 APPD. Jerry 92-12-17	容許公差 .XXX ±0.10 .XX ±0.25 .X ±0.38 X ±0.50 ANG ±3°	TOLERANCE	品名 ARTICLE SIDE ENTRY PCB JACK(8P8C)
版本說明 REVISION NOTE				圖號 DWG NO. 3001685800
KINSUN 慶陞		單位 UNIT mm		比例 SCALE 3/1
		張數 SHEET 1/1		版本 REV. A