

Size 11 Mini Hybrid Stepper Motors

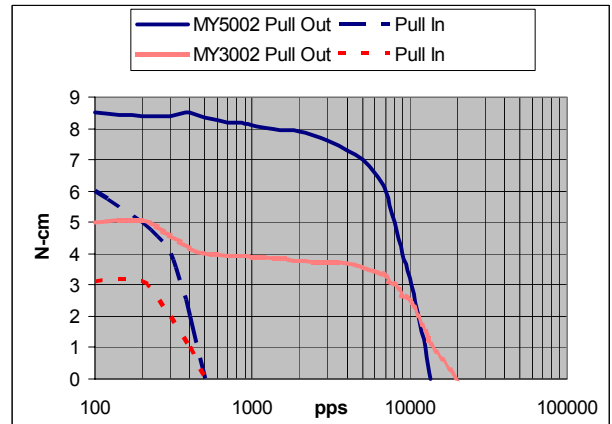

- High torque
- Light weight
- Compact size
- Low inertia
- High accuracy



General Specifications

Step Accuracy: Maximum angular deviation is $\pm 5\%$ of one step
 Radial Play: Maximum 0.02mm at 450g
 End Play: Maximum 0.08mm at 450g
 Insulation Resistance: Minimum 100M Ω at 500V dc
 Insulation Class: B
 Temperature Rise: Maximum 80°C

Wiring Diagram

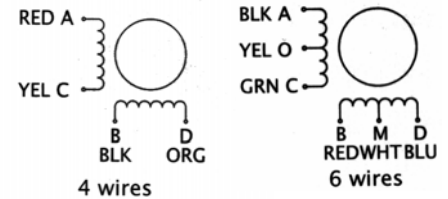

Model	Step Angle	Holding Torque	No. of Leads	Phase Current	Phase Resistance	Phase Inductance	Rotor Inertia	Detent Torque	Mass	Body Length (L)
	Deg	N-cm		A	Ω	mH	g-cm ²	g-cm	g	mm
MY3002	1.8	7	6	0.95	3.4	1.6	12	50	140	39.5
MY5002	1.8	9	6	0.95	4.6	2.3	18	80	200	50.3

Dimensions (mm)

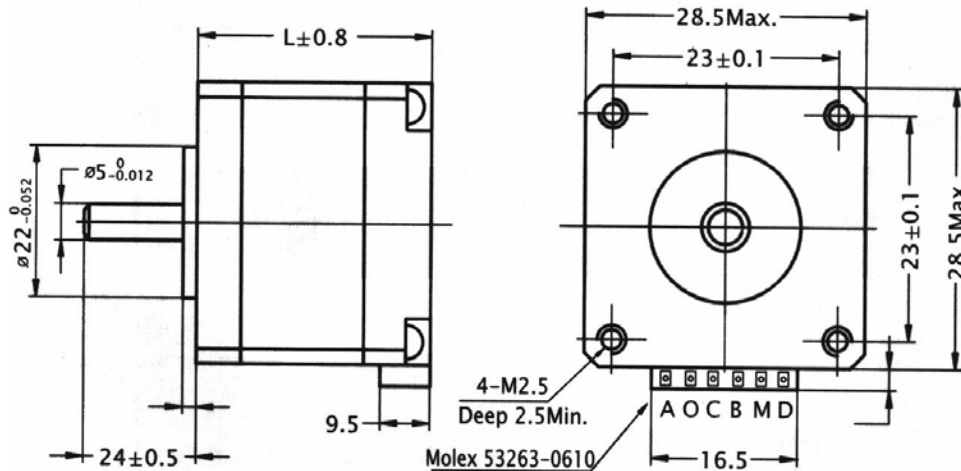

Size 14 Mini Hybrid Stepper Motor (with connector block)



- High accuracy
- Low noise
- Low inertia

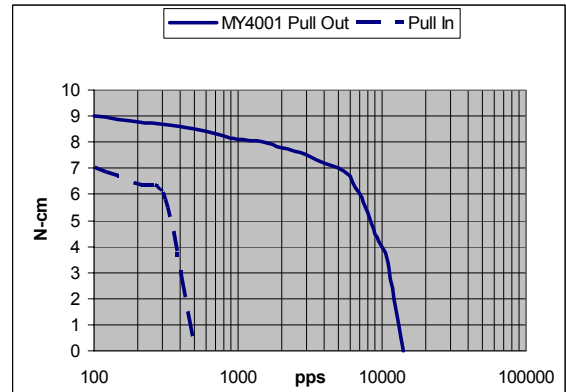

General Specifications

Step Accuracy: Maximum angular deviation is $\pm 5\%$ of one step
 Radial Play: Maximum 0.02mm at 450g
 End Play: Maximum 0.08mm at 450g
 Insulation Resistance: Minimum 100M Ω at 500V dc
 Insulation Class: B
 Temperature Rise: Maximum 80°C

Wiring Diagram

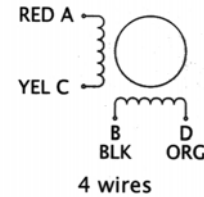

Model	Step Angle	Holding Torque	No. of Leads	Phase Current	Phase Resistance	Phase Inductance	Rotor Inertia	Detent Torque	Mass	Body Length (L)
	Deg	N-cm		A	Ω	mH	g-cm ²	g-cm	g	mm
MY4001	1.8	11	4	0.75	5.7	7	14	120	180	34

Dimensions (mm)

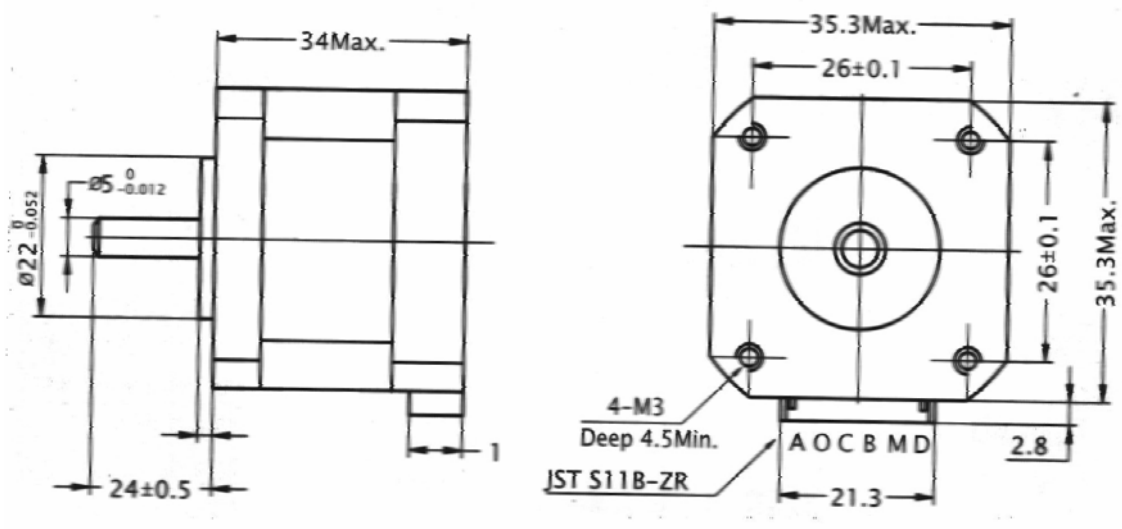

Size 14 Mini Hybrid Stepper Motors



- High accuracy
- Low noise
- Low inertia

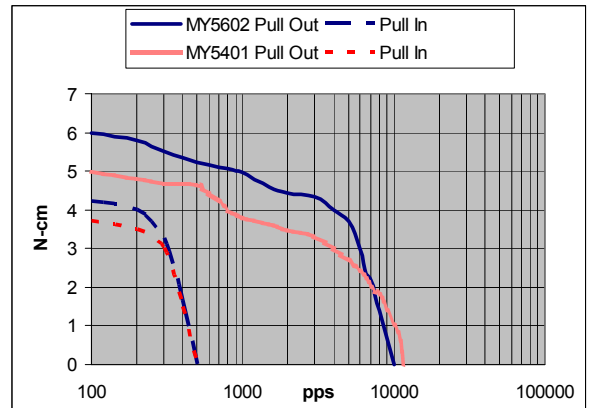

General Specifications

Step Accuracy:	Maximum angular deviation is $\pm 5\%$ of one step
Radial Play:	Maximum 0.02mm at 450g
End Play:	Maximum 0.08mm at 450g
Insulation Resistance:	Minimum 100M Ω at 500V dc
Insulation Class:	B
Temperature Rise:	Maximum 80°C

Wiring Diagram

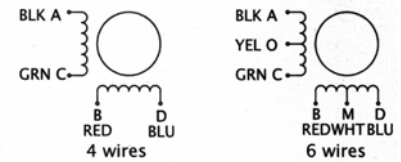

Model	Step Angle	Holding Torque	No. of Leads	Phase Current	Phase Resistance	Phase Inductance	Rotor Inertia	Detent Torque	Mass	Body Length (L)
	Deg	N-cm		A	Ω	mH	g-cm ²	g-cm	g	mm
MY5401	1.8	7	4	0.75	4.3	4	12	100	150	26
MY5602	1.8	8	6	0.76	10.5	4.8	12	100	150	26

Dimensions (mm)

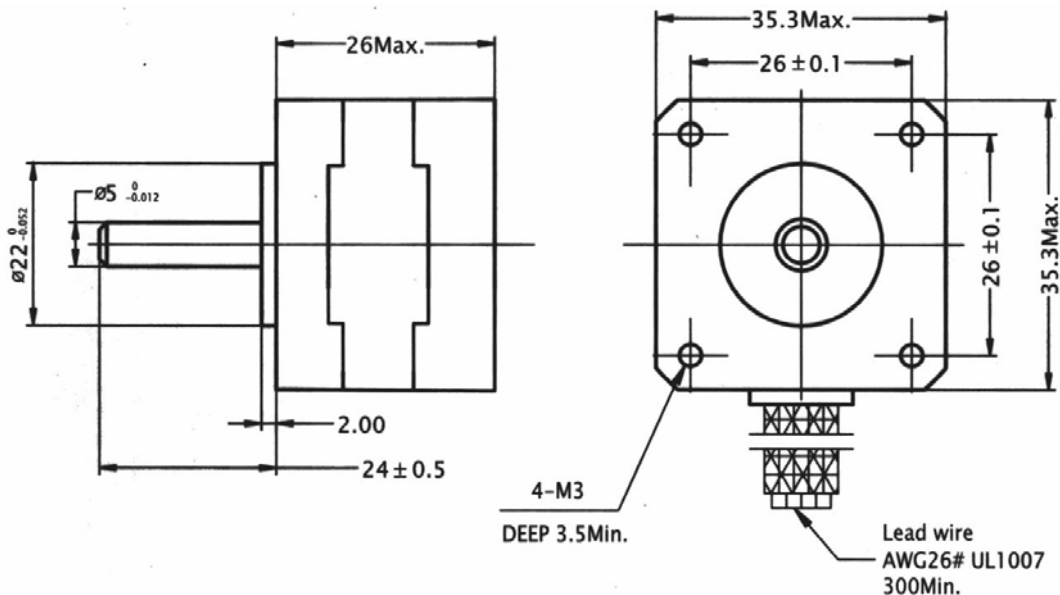

Size 14 Mini Hybrid Stepper Motor (with connector block)



- High accuracy
- Low noise
- Low inertia

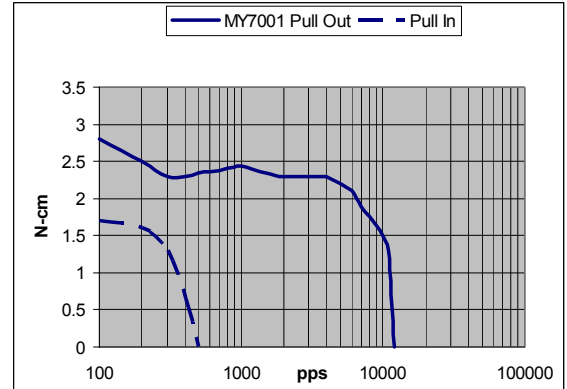

General Specifications

Step Accuracy: Maximum angular deviation is $\pm 5\%$ of one step
 Radial Play: Maximum 0.02mm at 450g
 End Play: Maximum 0.08mm at 450g
 Insulation Resistance: Minimum 100M Ω at 500V dc
 Insulation Class: B
 Temperature Rise: Maximum 80°C

Wiring Diagram

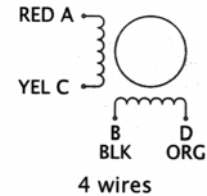

Model	Step Angle	Holding Torque	No. of Leads	Phase Current	Phase Resistance	Phase Inductance	Rotor Inertia	Detent Torque	Mass	Body Length (L)
	Deg	N-cm		A	Ω	mH	g-cm ²	g-cm	g	mm
MY7001	1.8	5	4	0.4	44	10	10	80	90	20

